

# PAM Soil and Drain



- SAINT-GOBAIN PAM subsidiaries
- Agents for Soil and Drain

To contact our Sales Manager:  
Tel: +33 (0)3 83 95 20 98  
Fax : +33 (0)3 83 95 29 51

SYNOPSIS Nancy 01/2012 - BAT-CAT-4A - 10.000 ex. The information, drawings and installation features in this document, has no contractual value. SAINT-GOBAIN PAM reserves the right to modify designs shown in this brochure to improve the products performance.



SAINT-GOBAIN PAM

Head Office &  
Soil and Drain Marketing Department  
91, avenue de la Libération  
54076 NANCY CEDEX  
FRANCE

Tel: +33 (0)3 83 95 20 00  
Fax : +33 (0)3 83 95 29 51



## CAST IRON DRAINAGE SYSTEMS

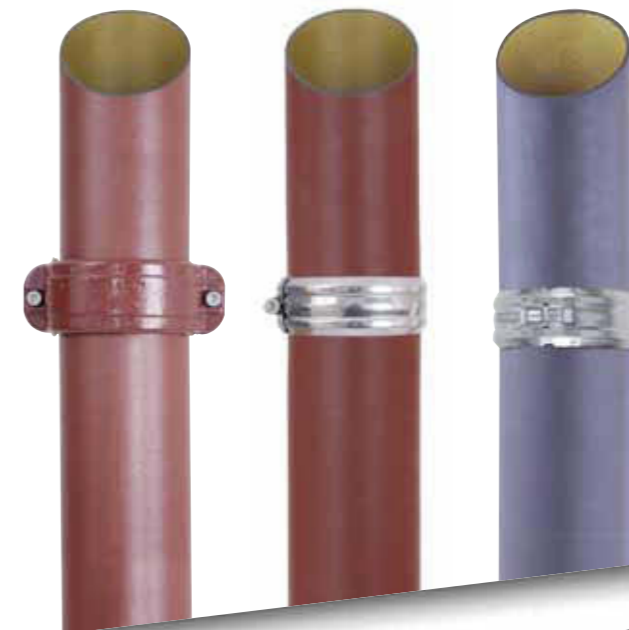

	<i>Page(s)</i>		<i>Page(s)</i>
<b>Section 1: Sales</b>	<b>28</b>	<b>Section 3: Specifier's Manual</b>	<b>87</b>
Why choose SAINT-GOBAIN PAM cast iron pipe systems	4-5	Installation features	88
Modular product range	6-7	Modifications to an existing installation	89
Ability to transport effluents	8-9	Jointing methods –Stainless steel couplings	90-91
Characterisation of common domestic applications	10	Couplings technical features	92
Recommendations	11	Couplings + grip collars: performance level	93
Characterisation of intense or professional uses	12	Jointing methods –Ductile iron couplings	94
Recommendations	13	Push-fit systems	95
Characterisation of external stresses and recommendations	14-15	Connection to other materials	96-99
Robustness and mechanical stress	16	Requirements and permissible pressure load	100-101
Resistance to thermal expansion	17	Ventilation & Roof penetration device	102-103
Water tightness	18	Multi waste manifold	104
Internal pressure resistance	19	Single stack branch	105
Ageing behaviour	20	Pipework stability	106
Compliance with standards and Quality marks	21	Access to the pipework	107
Fire safety	22-23	Bracketing: technical	108-110
Acoustics	24-25	Cast iron protection	111
Environment	26-27	Buried pipe systems	112-113
EPAMS syphonic system	28-29	EPAMS syphonic roof drainage pipeworks	114-115
Total cost of ownership	30	Standards specifications	116-117
		Discharge capability	118
		Commercial references	119
<b>Section 2: Products catalogue</b>	<b>31</b>		
<b>PAM SMU / ENSIGN S</b>			
Products identification – S ranges	32		
Pipes	33		
Bends	34-35		
Branches	36-37		
Double branches	38-39		
Long fittings	40-41		
Connectors	42		
Access fittings / Plugs	43		
Traps and ventilation	44-45		
Special fittings	46-47		
Compensators of movement	48		
PUSH-FIT ranges	49		
SME range	50-51		
EEZI-FIT	52-53		
<b>PAM SMU / ENSIGN Plus</b>			
Products identification –Plus ranges	54		
Pipes	55		
Bends	56-57		
Branches	58-59		
Double branches	60-61		
Branches / plug	62		
Traps/Access	63		
Reducer	64		
Couplings and Grip collars	65-73		
Connectors	74-75		
Bracketing	76-79		
Syphonic system EPAMS / roof outlets	80-83		
General terms and conditions of sales	84-85		



## Sales Arguments

### PAM SMU- ENSIGN CAST IRON DRAINAGE 1ST CHOICE FOR SPECIFIERS.

- **Secure** – strong enough to withstand the knocks in exposed areas (such as soil stacks on external walls), ground or traffic loads in buried applications
- **Non-combustible** – will not drip as molten, burning droplets, contributing to spread of fire and threat of injury to occupants and firefighters alike, or emit toxic smoke.
- **Silent in operation** – the quietest system on the market, ensuring a noise-free environment without adding lots of insulation
- **Minimal up-keep** – helps keep maintenance costs to an absolute minimum
- **Strength, safety and durability** for sustainable construction  
100% recyclable – protecting natural resources

# Why choose SAINT-GOBAIN PAM cast iron pipe systems?

As a leading manufacturer and the world's top-ranking exporter of cast iron pipe systems for building drainage applications, SAINT-GOBAIN PAM is an essential partner for designers of waste water and rainwater drainage systems.

The SAINT-GOBAIN PAM cast iron products are safe, easy to install and efficiently meet the requirements of project managers.

## Natural materials

Cast iron products for building drainage systems are made of an alloy of natural elements: iron, carbon and silicon. Cast iron is a natural product and it is manufactured entirely from recycled raw materials: scrap iron and cast iron which are enhanced by a second melting process. SAINT-GOBAIN PAM cast iron combines the traditional longevity of irons with outstanding technical and mechanical properties which remain stable over time and in all climates. Its robustness limits breakages and damaged supplies and its nature and density confer thermal and acoustic properties guaranteeing safety and comfort in use.

## Reliable targeted advice

Sound advice and technical assistance are among SAINT-GOBAIN PAM's strong points. During the preliminary project phase, advising designers to find the most suitable solution for their specific requirements and providing them with all the advice they need to get the best out of the products chosen. This may entail providing information required to draw up a safe and reliable project or - for special applications such as syphonic systems - a design study to optimise the future pipe system's performance.

### The Pipe Activity of the SAINT GOBAIN Group

*Sells complete and specified technical solutions for water supply, sewerage, municipal castings and building drainage.*

*Complete systems for waste water and rainwater drainage:*

*More than 200 product lines for pipes from DN 50 to DN 600, 1400 product lines for fittings and accessories and more than 450 product lines for couplings to help the project managers find the relevant solution for each construction project.*

*The Pipe Activity in figures:*

*Turnover: 2.2 billion €*

*More than 12 000 employees and 30 plants throughout the world*

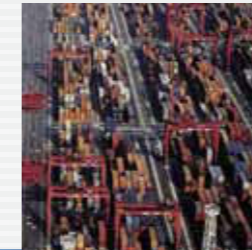

## Technical and sales service network

To optimise its customer service, SAINT-GOBAIN PAM offers an integrated network of subsidiaries, agents and distributors which can rely on dynamic and experienced technical sales teams to provide excellent customer support and the feedback required for the constant improvement of products and services. After-sales service is provided by highly versatile staff able to analyse customers' difficulties and find suitable solutions so that no problem remains unsolved.

*Please contact us for details of your nearest SAINT-GOBAIN PAM subsidiary or agent.*

## An efficient logistic support

Thanks to a 150 year experience of export sales throughout the world, SAINT-GOBAIN PAM daily ships a wide range of products to offer complete, operational solutions to its customers wherever they are.

## Precision of our industrial facilities

Offering precise technical solutions calls for regular high-quality production facilities. SAINT GOBAIN PAM endeavours to use the best available technology for its manufacturing operations. Working groups set up at its production plants ensure that the best industrial practices in the Pipe Activity are disseminated between all plants. Processes are fully mastered and automated to manufacture products whose quality is constantly being improved while controlling energy consumption.

# Modular product ranges

## Complete, compatible and consistent ranges

Pipes, couplings, fittings and accessories: SAINT-GOBAIN PAM offers a wide range of products combined with coatings and couplings for the construction of consistent pipe systems, benefiting from the outstanding robust properties of cast iron.

### The components

Pipe systems for drainage mainly consist of spigot systems comprising pipes (generally in 3m lengths) and fittings of various shapes (bends, branches, etc.).

Each SAINT GOBAIN PAM drainage product range targets specific applications and provide users with optimal safety, reliability and long service life.



### Joints

Spigot cast iron pipe systems are connected by mechanical metal couplings which can be assembled either with open straps or push-fit, depending on the model. These couplings are equipped with elastomer gaskets ensuring **flexible assembly** and **water tightness**.

Stainless steel couplings are available in different designs and can be equipped either with standard EPDM or NBR nitrile gaskets.

To meet specific requirements for pressure resistance grip collars or self-anchoring couplings can be used to lock those couplings.



The choice of couplings depends mainly on the applicable installation, operating constraints or on local preferences.

*A chart to help you make your choice is provided in the Specifier's Manual pp 92-93.*



## Coatings

For its product ranges, SAINT-GOBAIN PAM has conducted research on coatings and on the continuous improvement of their performance, so that customers can benefit from the properties of metal products suitably protected.

The benefit of more than 100 years of experience in pipe systems, substantiated by numerous tests conducted in operating conditions has resulted in the design of effective coatings, ideally suited to their specific purposes.

### ■ What are the coatings aiming at?

#### 1/ Durability

The cost of pipe material is assessed as part of a work site's overall budget but must also be considered with respect to the performance of the installation in the course of time.

The durability of cast iron systems has been demonstrated over more than a century of history. The purpose of coatings is to protect cast iron products against corrosion in order to further increase their service life. The full mastery and regularity of processes are of key importance in achieving the desired objective.

Spun pipes and cast iron fittings and accessories are provided with:

- external coatings to withstand aggressive environments (climate and – in the case of buried systems – ground conditions),
- inner linings to withstand thermal and chemical stresses from the effluents drained.

The coating processes used for hollow components like fittings and accessories ensure identical coating inside and out.



*Different ranges with adapted coatings exist to meet operating conditions with different intensities of constraints.*

#### 2/ Continuity

The principle adopted for a given product range is to offer consistent performances for pipes, fittings and accessories without any weak points, i.e. all the components of the pipe system provide the same level of performance in withstanding the constraints in each specific field of use.



# Ability to transport effluents

## Daily uses

### Resistance to domestic fluids:

Building waste water drainage systems - grey and black water- must be able to withstand the types of domestic effluents specified by EN 877 standard.

In recent years, however, changes have been noticed in the types of these fluids:

- Higher concentration of household detergents,
- Use of more aggressive hygiene products,
- Rise in operating temperatures.

The constraints on sanitary drainage systems are constantly increasing. SAINT-GOBAIN PAM coatings have been adapted to meet those constraints.

#### ■ Basic inner lining for pipes

The standard inner lining for PAM pipes is a sound, adherent epoxy resin which prevents the fluid transported from coming into contact with the metal.

The composition of the epoxy coating is controlled to minimise porosity, and its homogeneity is monitored in real time.

The smoothness of this coating increases flow rate and limits head losses.

#### ■ Basic coating for fittings and accessories

The common coating for fittings is an epoxy resin deposited through an cataphoresis process. However other processes can be used to meet specific requirements; fluid bed coating for ex.

The average thickness of standard coatings for fittings can vary from 70 µm to 150 µm, according to the targeted performance.



**Cataphoresis,** Fittings and accessories are coated with an epoxy resin deposited by cataphoresis which ensures a uniform deposit and excellent covering of edges. The optimised process by SAINT-GOBAIN PAM is based on a careful shot-blasting and entails interposing a chemical surface treatment during the coating cycle, between rinsing after shot-blasting and the cataphoresis bath in order to enhance the coating's covering power.

At the end of the cycle, the parts are oven-dried to complete the reticulation of the epoxy film.

Substantial improvements in:

- the epoxy film's adhesion to the cast iron,
- the corrosion resistance of the coated cast iron.

**FOCUS**

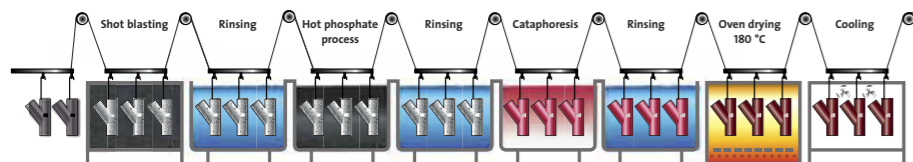

## Intense uses

### Resistance to corrosive or/and hot effluents

The inside of cast iron systems can be subjected to chemical and thermal aggressions when they transport fluids that are corrosive and/or at high temperatures.

■ **Superior inner lining for pipes:** two-part epoxy resin applied in two layers to obtain a film with no porosity.

### Resistance to aggressive backfills or severe climatic stresses

The outside of a pipe may also be subjected to the aggressive effects of climate or backfills, in the case of buried systems.

■ **External anticorrosion coating for pipes**

Zinc coating for pipe protection by galvanic effect.

**FOCUS**

### Zinc metallization

The zinc metallization is an active protection provided by the galvanic action of a zinc/iron cell.

Twofold action:

- Formation of a stable protective layer of insoluble zinc salts,
- Self-healing of any damage.

Zinc metallization is an excellent corrosion inhibitor and is extremely effective in extending the lifespan of products submitted to backfills or climatic stresses.

Tests carried out by the SAINT-GOBAIN PAM Research Centre: two identical notches are made on samples before immersing them in a highly corrosive medium.



Without zinc protection  
Corrosion beyond notch

With zinc protection  
Zinc salts on notch

### Solutions for intense stresses on fittings and accessories

According to the principle of continuity with no weak points, coatings for hollow components must withstand the same stresses as pipes.

There is an anticorrosion coating process for these parts to face major stresses, due to the fluids transported or to the environment.



■ **Superior coating for fittings and accessories: epoxy powder coating in fluid bed.**

A thick anticorrosion coating to guarantee long service life for products.

Preheated parts are moved through a tank containing epoxy powder in suspension, to be coated. They are then stove dried to ensure perfect reticulation of the polymerised epoxy film. Perfect control of both temperature and immersion time determines the coating thickness: 300 µm

For more than 100 years of testing and market research, SAINT GOBAIN PAM has built up great expertise in cast iron. Increasingly effective coatings have been developed to keep pace with the changing utilisations and requirements.

# Characterisation of common domestic applications

For conventional grey water, black water and rainwater applications, For systems installed above ground, in ducts, raft foundations or included into concrete.

To provide clearer guidance on the chemical resistance of S range in domestic applications, SAINT-GOBAIN PAM has carried out 20 additional tests to the EN 877 Standard requirements (see p 116) on detergent products (floor cleaning product, laundry detergents...) and special products (stain remover, drain cleaner...) of common use. The additional tests also aimed at assessing S and Plus ranges boarders.

The tests were carried out on samples, under the temperature of use recommended by the manufacturers and where it was relevant, up to 70°C since hot water is normally supplied in dwellings around 50 – 60°C.

After stopping the test, the pipes and fittings shall be washed immediately to eliminate any stains and the coatings shall be examined with regard to blistering and rusting both according to ISO 4628-2 and 3. (Accepted levels according EN 877)

The duration of the test is considered equivalent to the extrapolation of a real chemical stress undergone during 7 or 10 years (a 10 to 15 min stress per day). This test method however simulates a severe stress since the samples lies in direct contact with the solution, the temperature is being maintained and the test includes no rinsing over its duration.

		Dilution*	pH	23°	50°	65°	70°	Test duration
SALT WATER *	Same as sea water	30g/l						
DETERGENTS								28j
Laundry detergents	Phosphate free wash	2ml / l	7,7					28j
	Softener	2ml/l	7,6					28j
Dish washer detergents	Washing tablet	3g/l	9,3					28j
	Washing gel	3g/l	9,8					28j
	Washing up liquid	2ml/l	7,65			not applicable		28j
Stain remover	Type "ACE GENTLE"		7,7					28j
COMBINATION	Wash + stain remover	2ml/l + 3ml/l	7,7					28j
	Wash + Softener	2 ml + 3ml/l	7,7					28j
CLEANING PRODUCTS	Floor cleaning product	8ml/l	8,2				not appl. cable	28j
	Bleach	8ml/l	8,25			not applicable		28j
WC CLEANERS	Toilet bowl cleaner (gel)	20ml/l	5,45			not applicable		28j
	Drain cleaner gel	0,33 ml/l	13			not applicable		4j
	Liquid descaler	80ml/l	2,07					28j

\* according to the manufacturer

## Recommended ranges for these applications

S ranges and socket ranges, SME or EEZI-FIT, equipped with EPDM gaskets are fully adapted to fit all the constraints involved in the above-mentioned uses.

**S – SME systems: complete ranges of cast iron pipes & fittings and their gaskets.**

SMU/ ENSIGN spigot range: 11 diameters from DN 50 to DN 600

SME, socket range: 5 diameters from DN 50 to DN 150

EEZI-FIT: new range of socket fittings and couplings in 100 mm and 150 mm diameter, designed to be quick and simple to assemble for above ground gravity sanitary installations.



# Recommendations

Resistance to conventional domestic fluids, in compliance with EN 877

Grey water, black water and rainwater



■ S range Pipes  
Basic external coating



■ SME range Pipes  
External zinc coating

Basic external primer paint:  
Acrylic paint, red brown colour  
Dry film average thickness: 40µm  
Basic inner lining:  
Two part epoxy resin ochre colour  
Dry film average thickness: 130µm in one layer



■ Fittings and accessories: S, SME and EEZI-FIT\* ranges  
cataphoresis coating, red brown colour



\*The EEZI-FIT socketed fittings are installed with spigot S range pipes.

# Characterisation of intense or professional uses

## Above and below ground waste water drainage for aggressive discharge.

**Aggressive effluents are characterized by:** Their content (acids, bases, solvents, hydrocarbons...), their combinations and their temperature. Owing to its anti-corrosion thick linings, the Plus range provides a greater chemical resistance and is particularly well adapted for intense uses.

Hot water resistance: 24 h at 95°C continuous and thermal cycles (1500 cycles of 5 min between 15° and 93° C)

Salt spray resistance: 1500 h

Chemical resistance: 1 < pH < 13

Compulsory use of PLUS range+ EPDM gasket				
Acids and bases, saline solutions common temperatures of use				
	pH	20°C	60°C	80°C
<b>WATER</b>				
Salt water NaCl 30g/l	5,6			
Demineralised water	6,6			
Waste water	6,9			
<b>DETERGENTS</b>				
Cleaning supplies 10%	7,4			
Phosphate free washing liquor	7,7			
Dishwasher cleaner 5% vol	9			
Ammonia solution 10%	9,5			
Pure Ammonia solution	10			
<b>SPOT REMOVER /OXIDANTS</b>				
Type "ACE DELICAT" 5%	4,2			
Type "BECKMANN" tablet/5l	9,3			
Type "BLANCO" tablet/5l	10,3			
<b>MINERAL ACIDS</b>				
Hydrochloric HCl 5%	1			
Sulphuric H2SO4 10%	1			
Sulphuric H2SO4 1%	2			
Phosphoric H3PO4 10%	1,3			
Phosphoric H3PO4 5%	1,8			
Phosphoric H3PO4 2,5%	2			
Nitric HNO3 10%	2			
<b>ORGANIC ACIDS</b>				
Lactic 10%	1,1			
Lactic 1-5%	2,2			
Citric 5%	2			
Vinegar 30%	2,9			
Vinegar 10%	3,2			
<b>BASES</b>				
Soda NaOH	12			
Soda NaOH	13,6			
Ammonia NH3	12,1			
Potash KOH	13,6			
Bleach 10%	12			
Bleach 30%	12			
Bleach 100%	12,5			
<b>SALTS</b>				
KCl 3%	4,2			
NaH2PO4 3%	4,2			
(NH4)2SO4 3%	6,7			



Compulsory use of PLUS range+ NBR gasket				
Solvents at common temperatures of use and hot oils				
	pH	20°C	60°C	80°C
<b>SOLVENTS (except Acetone)</b>				
Ethanol, methanol, glycol	—			
Xylene	—			
White Spirit	—			
Gasoline, diesel, petroleum	—			
Lubricants, petroleum derivatives	—			
High temperatures OILS				

### For non described or intense industrial uses, please contact us

In the application table above, light green means S range still possible, heavy green means Plus range compulsory.

This being two-dimensional, the boarder between S and Plus ranges is only determined by the type of the fluids and the operating temperature. But the selection of the appropriate range is also directly related to the duration of daily exposure, the reason why we called this chapter intense of professional use.

The combination of high pH products (base and alkaline products) and high temperatures systematically calls for the use of the Plus range.

Spigot Plus range: 11 diameters from 50 to 600 mm.

## Recommendations

### Resistance to aggressive and/or hot effluents

#### ■ Plus range Pipes

Inner lining: two part epoxy resin ochre colour.

Two layers for a lining with no porosity. Dry film average thickness: 250µm in two layers.

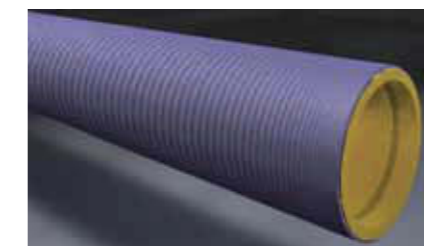

#### ■ Plus range Fittings and accessories

Thick polymerised epoxy powder coating, grey colour. Dry film average thickness: 300µm.



Remarks :

- To transport effluents containing acids, bases or saline solutions at common operating temperatures, the systematic use of the Plus range equipped with couplings with EPDM gaskets is recommended.

- For solvents, hot oil and where hydrocarbon traces are to be feared, the systematic use of the Plus range equipped with couplings with NBR gaskets is recommended.

# Characterisation of external stresses

## Below ground waste water drainage systems exposed to environmental stresses.

### Buried systems – chemical stress due to aggressive grounds.

The buried section of a pipe may be laid in non-homogenous grounds or corrosive soil.

When protected through galvanic effect, the pipework can be installed without requiring systematic soil studies.



# Recommendations

## Resistance to ground chemical stresses

### Plus range Pipes

External coating: anti-corrosion flame applied zinc metal 130g/m<sup>2</sup> + acrylic paint, grey colour  
Dry film average thickness: 40µm



### Plus range Fittings and accessories

Thick epoxy powder coating, grey colour  
Dry film average thickness: 300µm.



### Buried jointing

Buried systems are subjected to ground loadings which can cause shearing strain on couplings. For these applications, it is therefore recommended to use wider couplings and for steel couplings to select their "all stainless steel version" to avoid corrosion due to the ground aggressiveness.



## Above ground grey water, black water and particularly rainwater drainage systems exposed to climatic stresses.

### Outdoor or façade exposures.

In operation, outdoor waste water and rainwater systems can be subjected, according to climate conditions to ultra violets radiations, saline mist, condensations or freezing-thawing cycles.

The drainage systems must fit their purpose despite adverse exposures.

Zinc coating allows the pipes to withstand climatic stresses even better and extends their service life.

# Recommendations

## Resistance to severe climatic stresses

### Plus range or SME range (see p 11)

But also,

### Decorative 'Residentielles' rainwater stacks

External coating: anti-corrosion flame applied zinc metal 130g/m<sup>2</sup> + acrylic paint, beige colour

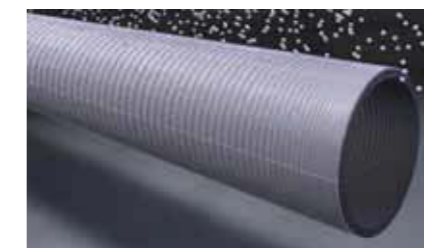

## Complete range of fittings and accessories for rainwater systems

### Residentielles range

2 possible shapes: round or fluted  
And 2 profiles: straight or with a shoe.

2 lengths : 1 m – 2 m

3 diameters : 75, 100 and 125 mm

- Push-fit assembly
- Consistent performances of pipes and fittings coatings
- Two possible fixing methods: conventional brackets or hidden wall fixing to protect the façades aesthetic appearance.

Complying with EN 877, the decorative Residentielles rainwater ranges add value to your properties and enhance aesthetic appearance.





# Robustness and mechanical strength

Pipe system components must withstand hazards before they reach the job site such as accidental impact before and during installation, during storage, handling and transit. In service, outdoor exposed pipes may be damaged by accidental impacts or vandalism. To avoid breakages, which can be expensive, or minor stress cracks which can have serious consequences in operation, the choice of material should be carefully considered.

## Impact strength and crush resistance

Cast iron is well-known for its robustness. The quality of PAM products is ensured by careful control of both metal composition and manufacturing process.

The spinning of pipes in the De Lavaud process, followed by heat treatment, gives these products outstanding mechanical properties.

Key mechanical characteristics required by the standard EN 877 are controlled by three tests, carried out on pipes when coming out of the heat treatment furnace to assess tensile strength, ring crush resistance and hardness.

In addition, operators have opted to maintain a further test which gives a good indication of the quality of heat treatment: the guillotine impact test.

**FOCUS**

### De Lavaud process

In this process, a constant flow of molten metal at perfectly controlled temperature and composition is gradually input into a steel mould rotating at high speed. The mould external wall is cooled by circulating water and the evenly distributed molten metal cools on contact with the wall before extraction.

The process is characterised by a quick cooling that gives a finer solidification matrix and thus a more homogeneous metallurgical structure.



#### Heat treatment

The spun pipes are placed and rotated in a heat treatment furnace at 950°C and then gradually cooled again. This step is essential to the process as it transforms the cast iron's metallurgical structure. The reduction of iron carbides and the increase of ferrite content considerably improve the mechanical properties of cast iron and reduce its surface hardness. The graphite of the cast iron resulting from the SAINT-GOBAIN PAM process forms clustered graphite, halfway between lamellar and ductile iron.

THE PIPES	Saint Gobain PAM process	Others	EN 8777 requirements
Tensile Strength on samples in MPa (average value)	300	270	200 min.
Ring Crush Strength in MPa (average value, DN 100 pipes)	450	360	350 min.
Brinnell Surface Hardness in HB degree (average value)	220	245	260 max.

These results indicate greater resistance to impacts and crushing, easier machining and cutting. This also means the products are easier to install on job sites.



# Resistance to thermal expansion

Most solids expand when they are heated and are liable to elongate under temperature increase.

For pipe systems made of materials that are subjected to high levels of thermal expansion, precautions have to be taken at design stage.

Cast iron which expands very little does not require specific bracketing nor expansion collars. It makes the specifier's design work easier and avoids extra cost at installation stage.



## Thermal expansion of plastics

To allow expansion without damaging the drainage network, plastic pipe systems demand specific accessories – expansion collars or joints, brackets allowing axial movement, in general one out of two.

If these precautions were not taken, expansion could be absorbed by the pipework and cause distortion.

Cast iron can do without these expensive accessories. It makes the design work easier and decreases the risk of mistakes at installation stage.

These properties of cast iron pipe systems are also valuable for engineering structures such as bridges where important expansions have to be carefully addressed to secure the construction project.

## Thermal expansion coefficient of cast iron and other materials

The thermal expansion coefficient for cast iron – 0.01 mm/m/°C – is very low and very similar to that of steel and concrete; the building and the pipe systems will move and will expand together.

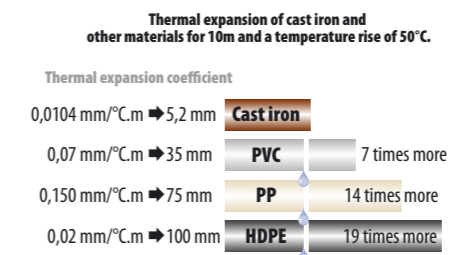

For cast iron, the bracketing system is designed to only carry the weight of the pipe and its content, which makes the designers work easier. (See our recommendations in the Specifier's Manual p 108).

Plastic pipes, for themselves, expand considerably with increasing temperature. Their bracketing system must be designed and adapted accordingly, as it can deeply affect the stability of a pipework and its performance over time.

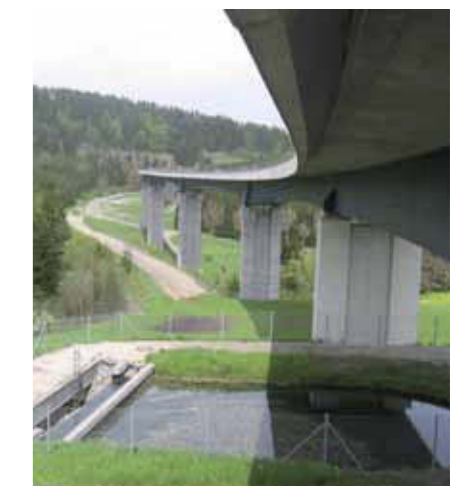

# Water tightness

Sanitary drainage systems, whether exposed or not, must remain water tight over time. Any defects can cause serious damage, leakages, dripping or slow permeation and generate costly repairs, and disruption. SAINT-GOBAIN PAM cast iron mechanical assemblies are designed to reach easily instant water tightness and are not dependent on process control (gluing or welding...)

## Water tightness of cast iron systems

Cast iron is a dense and non-porous material. Cast iron pipe systems are water tight and impervious.

Cast iron components, straight and rigid are assembled using metal couplings fitted with elastomer gaskets which ensure that the system is completely water tight.

Assemblies benefit from a conventional approach. Made with only simple tools, they allow installation tolerance with no risk of leakage.

This ease of installation ensures that the specified performance is always obtained, even in adverse conditions - unlike for plastics when either gluing or welding can be affected by installation hazards (ambient conditions such as temperature or damp) or when personnel with special skills are required.

## Water tightness over time

Failure of water tightness can occur on drainage systems in operation. They are then due to breaks, misalignments, crushes or cracks...

Long-lasting water tightness depends on two main factors:

- **No deterioration of pipes:**

Cast iron is highly resistant to ovality. Their specified mechanical properties and their stability enable cast iron systems to withstand operating stresses extremely well.

- **No deterioration of assemblies:**

Elastomers are carefully selected for the long-term stability of their physico chemical characteristics to ensure the lasting water tightness of the rubber gaskets.



The S and Plus ranges, being assembled and anchored, have successfully passed a high-pressure jetting test: cleaning pressure of 120 bar from the pump, which means 100 bar at the nozzle outlet, without leakage or misalignment.

## Water tightness and maintenance

Sometimes blockages occur in drainage networks; the pipework materials must be resistant so that the maintenance is easy.

The S and Plus systems can resist without damage all normal maintenance processes including high-pressure jetting. They have been submitted to a high pressure test according to the Swiss standard SN 592 012.

*Robustness and dimensional stability of cast iron components along with the careful selection of elastomer ensure pipe installations give high performance and long service life.*

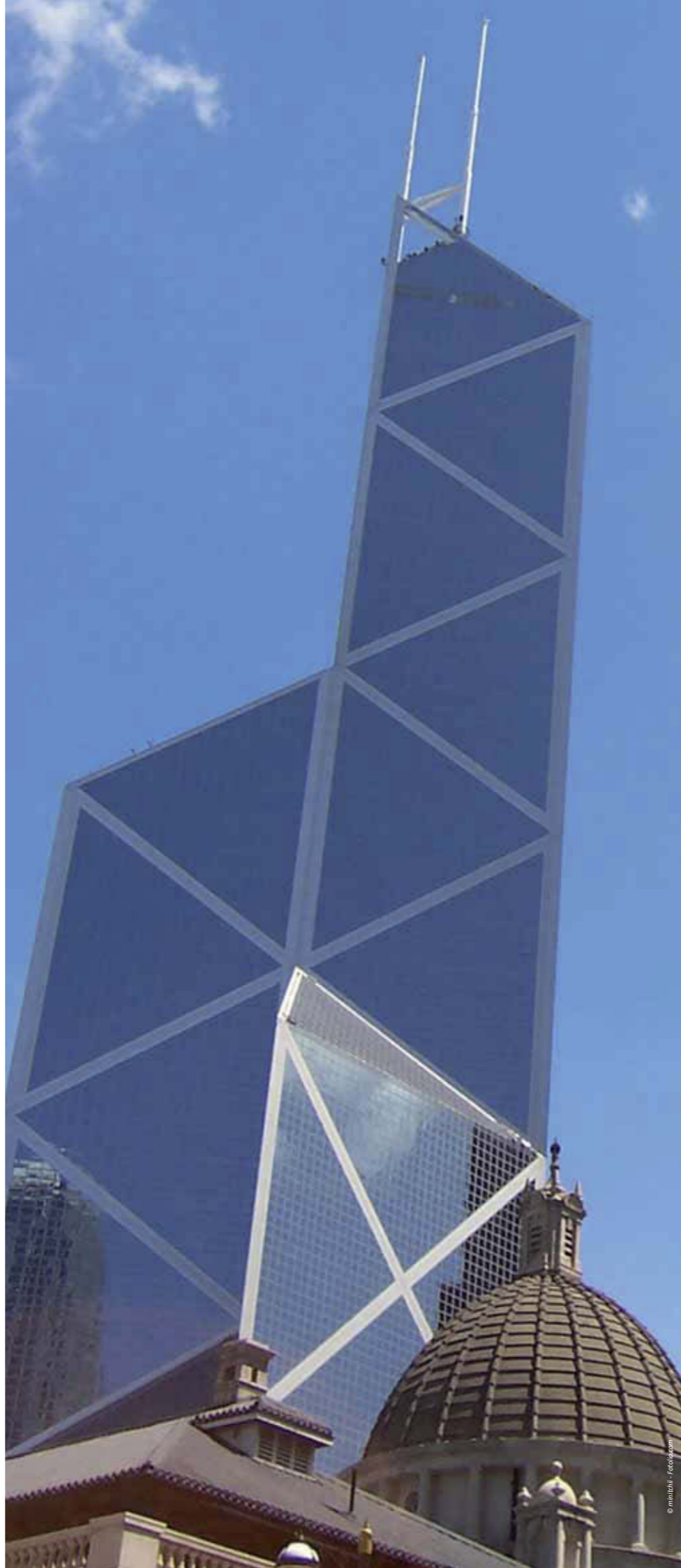

# Internal pressure resistance

Internal overpressure in drainage networks rarely occurs and is always accidental. Thrust efforts in the overloaded sections have to be addressed to guarantee both water tightness and mechanical stability.

As the robust cast iron components can address any pressure hazard, then the couplings will be submitted to the strain.

The quality of the couplings and their careful selection according to their field of use will prevent misalignment or disconnection of the pipework.

## Resistance of the couplings to hydrostatic pressure

- ♦ **Standard pressure mechanical couplings:**

Waste water drainage systems – which differ from rainwater drainage systems as regards pressure – are connected to sanitary appliances installed on each storey which may serve as outlets in case of accidental overloading (due to blockages, for example).

The pressures that occur cannot therefore exceed the pressure corresponding to the height of one storey, i.e. about 0.3 bar.

The couplings we describe as "standard" are perfectly suitable for this common type of application.

- ♦ **High-pressure mechanical couplings:**

In some rare cases, a waste water drainage system may pass through a number of storeys without any outlet and there could be a risk of overloading (blockage due to operation or saturation of the sewer main).

The pressure resistance required to ensure that these systems remain leaktight and stable in such cases depends on the height of the water column liable to occur and calls for high-pressure couplings able to withstand the resulting pressure (up to 10 bars).

*See p 100 in the Specifier's Manual section.*



### FOCUS

## Specific points of the pipe work: Resistance to end thrust efforts

Some specific points on a pipe system may be subjected to thrust loads due to changes of direction or gradient, especially branches and plugs. To avoid any risk of disconnection or slippage of the pipe components, these efforts must be addressed and the sections at risk must be anchored:

The section of pipe has to be held between two fixed points, by using stack supports, for example.

And a self-anchoring coupling or an ordinary coupling anchored with a grip collar shall be used.

*For full installation details, see the Technical specification section.*

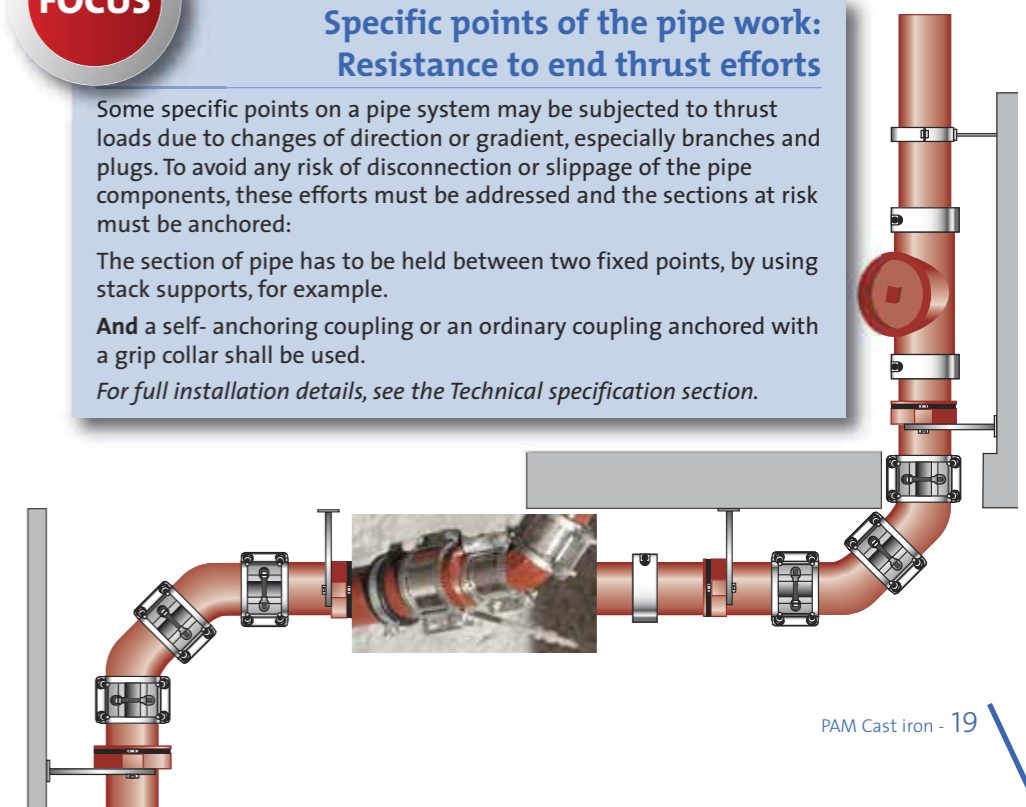

# Ageing behaviour

As components that are integrated in buildings, waste water and rainwater drainage systems must remain in a serviceable condition over the long term in spite of adverse operating conditions.

Ageing refers to any gradual, irreversible change in a material's structure and/or composition, liable to affect its behaviour or serviceability.

When a material is selected, the stability of its properties ensures operational reliability over time.

## Stability of cast iron mechanical properties

The ageing of a material may be due to its own instability, to environment or chemical stresses, to mechanical strains, or a combination of any of those causes.

It is an established fact that cast iron offers long service, owing in particular to the stability of its mechanical properties over time.

### - Cast iron is not sensitive to thermal ageing

- Its mechanical strength remains stable.
- Its thermal expansion is very low compared to plastics.
- Cast iron pipe systems are not liable to creep at operating temperatures.

### - Cast iron does not deform under mechanical strain

- Its ring stiffness (cold measurement) around 70 Mpa is not affected by temperature and is 8 times that of PVC pipes. It is mainly appreciated for buried pipework.
- Its longitudinal stiffness, which eases bracketing and protects water stream in horizontal sections, remains intact. Its Young modulus of elasticity is ranking from 80 to 120 GPa vs 2 to 5 GPa for PVC.
- Cast iron's tensile strength is 8 times that of PVC: 200 MPa vs 25. (residual resistance, after 50 years according to the standards). This property is of utmost importance in case of network overloading.

The properties of cast iron ensure the stability of systems and long lasting operational safety.

## Resistance to climatic stresses

The properties of materials are extremely important when they are stored or exposed to adverse conditions (extended

exposure to ultraviolet light or wide temperature variations...).

Cast iron undergoes no structure modification under climatic stresses.

## Ageing of polymers:

**FOCUS**

### Deterioration of mechanical properties under temperature stress.

Under temperature effect plastics can suffer two kinds of deteriorations, including at operation temperatures:

- **Creeping** is an irreversible elongation under the combined action of both temperature and an important mechanical strain. Plastic pipe system like PVC or HDPE are particularly sensitive; in horizontal sections, they can bend between two support brackets under their own weight.
- **Modification of the elastic limit:** most plastic materials will soften under temperature increase. Under temperature decrease on the contrary, they crystallize. PVC for example become rigid and may crack under mechanical strain – their operating temperature range is generally between -20°C to 80°C, but depending on their nature, the range can be much narrower.

### Photochemical ageing

Depending on their nature, climatic stresses (such as solar radiation, damp or heat) will cause more or less severe photochemical ageing to plastic materials.

They can just alter their surface finish, but also deeply modify their mechanical properties and then adversely affect their serviceability.

The same can happen through slow chemical attack by solvents or even in aqueous media.



# Compliance with standards and quality marks

## Quality Management System

The plants which manufacture our products are certified for their compliance with the ISO 9001 standard which specifies requirements for a quality management system. The scope of this standard covers product design and development and the quality control of procurements, training, and administrative follow-up.

## Products performances

PAM pipe systems comply with European standard **EN 877**, applicable to a system (cast iron pipes and fittings, couplings and accessories for building drainage). **This standard, specifying the technical requirements for cast iron products, is the most demanding in the market.**

In particular, it lays down requirements regarding:

- Reaction to fire (product range),
- Resistance to internal pressure,
- Dimensional tolerances,
- Tensile strength, crushing strength,
- Joints and their leaktightness,
- Inner lining and external coatings and their suitability.

It also defines test methods and the quality management system. EN 877 is a self-declared standard; the manufacturer is allowed to self declare that his product complies with this standard.

**Only compliance with EN 877 that is validated by a third party for all criteria and periodically tested can guarantee the performance of the systems you specify.**

The quality of the SMU / ENSIGN S, SMU / ENSIGN Plus, SME and EEZI-FIT product ranges are guaranteed by the following marks of approval: BBA, Kitemark and/or Marque NF.

	European standards	International standards
Cast iron pipes and fittings, their joints and accessories for the evacuation of water from buildings. Requirements, test methods and quality assurance	EN 877	
Cast iron drainage pipes and fittings (spigot)		ISO 6594
Elastomeric seals - Material requirements	EN 681-1	ISO 4633
Requirements for a quality management system design, product development, production, installation and after sales support		ISO 9001
Environmental management system Requirements with guidance for use		ISO 14001
Testing standards		
<b>Fire tests</b>		
Fire classification of construction products and building elements. Classification using data from reaction to fire tests	EN 13501	
Reaction to fire tests for building products - Part 1 Building products excluding floorings exposed to the thermal attack by a single burning item	EN 13823	
<b>Measurement of noise</b>		
Laboratory measurement of noise from waste water installations	EN 14366	

# Fire safety

## Protect people and property

For fire safety in a building, the major responsibility rests with the project manager who must respect the Regulation in force.

In buildings at risk like multi storey buildings, materials with reduced flammability should be selected to apply precautionary principle.

The following two concepts are applied as regards fire safety:

Reaction to fire and fire resistance.

### Reaction to fire

It is the instant behaviour when a fire breaks out, its propensity to ignite or feed a fire. This behaviour is assessed on the basis of standardised tests and described in an EUROCLASS classification.

**FOCUS**

### CE marking

The mandatory CE marking is required by the European Construction Products Directive (DPC 89/406/CEE) and must be affixed to products before allowed pass into the European market.

- To ensure their free movement within the European Union and the EEA.
- To ensure those products do not constitute a hazard for the occupants or users of buildings.
- To implement the same safety criteria throughout Europe it is referred to **Essential requirements** concerning public health, safety and consumer protection.

The CE marking on products certifies that they comply with the harmonised part of their reference standards.

### Reaction to fire for PAM cast iron systems

For drainage systems, **safety in case of fire** is the only essential safety requirement.

For cast iron systems, the tests and technical specifications are defined in the amended standard EN 877, and the section

"Reaction to fire" alone requires a **mandatory certificate, issued by an independent laboratory, to obtain CE marking.**

Cast iron as a material itself is classified as A1 in the Euroclass classification for reaction to fire.

In tests carried out by the CSTB accredited laboratory, the **SAINT-GOBAIN PAM cast iron ranges** (pipes, fittings and accessories including elastomer gaskets and coatings) received the following excellent Euroclass ranking:

### A2 -s1, d0

For smoke emission and the production of flaming droplets, the SAINT-GOBAIN PAM products respectively achieved the highest possible rating: **s1 et d0.**



EUROCLASS classification is based on harmonised test methods and defines a reaction to fire ranking so to make it possible to compare construction products. A1 and A2 are reserved for products that are not, or only slightly, combustible.

So, cast iron remains one of the safest drainage material for fire safety.

*SAINT GOBAIN PAM cast iron ranges comply in every respect to the standard EN 877.*

*This compliance is validated by complete Quality Marks, is periodically tested by accredited third part laboratories and brings you the performance guarantee for the systems you specify.*

#### Sub-Class SMOKE production

- s1: Low smoke production
- s2: Medium smoke production
- s3: High smoke production

#### FLAMING DROPLETS sub-classification

- d0: No flaming droplets
- d1: Flaming droplets that persist for less than 10 s
- d2: Flaming droplets

EUROCLASSES			Former French classification
A1	-	-	Incombustible
A2	s1	d0	M0
A2	s1	d1	
A2	s2		
A2	s3		M1
B	s1	d0	
B	s2	d1	
B	s3		
C	s1	d0	M2
C	s2	d1	
C	s3		
D	s1	d0	M3
D	s2	d1	
D	s3		M4 no flaming droplets
Classes other than E-d2 and F			M4



Many buildings are not protected enough against fire hazards. It means that fire can spread rapidly, can destroy the building and the properties in a few hours and jeopardize the occupants' lives.

When a fire breaks out, the first objective is to slow down its spreading both horizontally and vertically.

Drainage systems must be selected so that they resist the passage of fire and do not feed it.

### Fire resistance

It is a construction component's ability to withstand fire for a given period of time and to retain its serviceability in the event of fire.

If a fire breaks out, it is essential to prevent any early collapse of the structure, and then to limit the extent of the damage so as to ensure that occupants can be evacuated and/or the belongings will be protected.

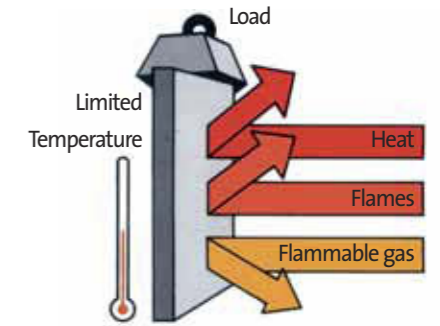

**FOCUS**

### Compartmental principle

Fire Safety Regulation for buildings, when it exists is based on **compartmental principle.**

Within a building, a compartment is a fire rated space designed to stop the fire for a given period of time. The fire-stopping requirement for walls (shells and slabs) is generally 2 hours or less – and exceptionally 4 hours.

The requirement depends on the nature of the building and its level of occupancy, and can be very different from one country to another.

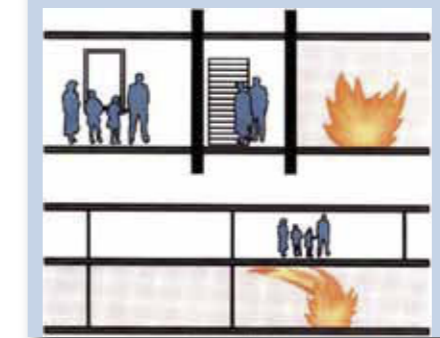

### Waste water drainage systems and fire stopping requirements

Drainage systems passing through structures designed to withstand fire, should not provide open breaches. For a given time, specified in the applicable Regulations, they should not allow the passage of fire, smokes, heat or combustion products from one compartment to the other.

For plastics, the fire-stopping rule consists in "plugging the hole". This function is ensured by the fire collars recommended by the manufacturers. Plastic materials which are highly sensitive to heat will not withstand the fire, will not remain in place, even in the case of a contained fire.

As shown by laboratory tests, if the fire collars are not activated or do not operate correctly, and depending on the type of plastic material, the greatest hazard is posed by combustion products (flaming droplets) or smokes.\*

### SAINT-GOBAIN PAM's solutions

SAINT GOBAIN PAM cast iron, non-combustible material has a melting point over 1000°C.

In most cases it requires no additional fire protection.

SAINT-GOBAIN PAM carried out a non-exhaustive series of tests on its cast iron pipe systems in order to make precise recommendations for fire resistance requirements up to 240 minutes (4 hours).

A full report has been published. In every configuration, solutions exist be they either plaster or mineral wool protections.

*SAINT-GOBAIN PAM cast iron is non-combustible, it does not feed the fire, nor gives off either gases or smokes liable to delay fire fighters or damage other equipment.*

\* Tests carried out in March 11th 2004 at the Testing Center for Materials (MPA) in Northern Rhineland-Westphalia in ERWITTE-Please consult us to get the movie of these fire tests.

# Acoustics

Noise in buildings is considered to be detrimental to health and the quality of life. Efforts have been made, in the last 30 years, to attenuate the sounds coming from the street, worsening the perception of the sounds emitted within the buildings. Heat insulation policies aiming at reducing energy consumption will also heighten these perceptions.

Among the priority criteria in the comparative performances of drainage materials, acoustic performance is reckoned to be second only to fire safety: cast iron pipe systems have intrinsic acoustic properties. Owing to the development in accessories equipment, they offer outstanding performances.

## Pipe systems and equipment noise

Noise from waste water pipe systems is classified under the regulation in the "equipment noises".

Noise originating from pipe systems is due to the sound energy produced by water/air turbulence, but mostly by the mechanical effect of the water-flow on the internal pipe walls.



## Acoustics and SAINT-GOBAIN PAM cast iron pipe systems

### Airborne noise

When a material is dense and thick, the pipe walls prevent air transmission; as is the case with cast iron which offers intrinsic acoustic properties.

### Structure-borne noise

When the noise produced in a pipe is not transmitted by the air, the residual noise is transmitted by structural vibrations.

Whilst the mass of the cast iron limits the vibratory level, the junctions and fixing to the building will propagate noise. **Objective: Dampen the vibrations at the connections with the solid structure.**

## FOCUS

## Noise and regulations requirements

Noise is an energy affecting air pressure and is transmitted through vibration. Sound is measured in decibels (dB) using a nonlinear scale.

For noise from equipment apparels, the following categories are identified and measured:

• **Airborne noise:** air vibrations that are propagated

In the case of waste water pipe systems, this noise is mainly heard in the room where the pipe is located.

• **Structure-borne noise:** vibration of a building's structure

This noise will be noticed in rooms adjacent to the pipe.

Statutory requirements on "equipment noise" for structure-borne noise differentiate between noisy rooms and quiet rooms with sound-attenuation requirements. For noisy rooms the noise level requirements is generally 35 dB or more. For quiet rooms, which are generally living, resting rooms and work rooms, the noise level requirements are generally around 30 dB, in cases where noise regulations exist.

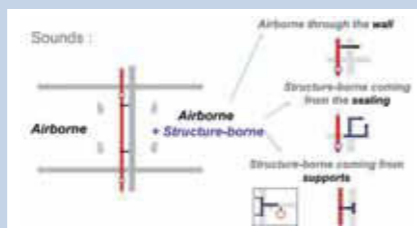

Acoustic comfort is a differentiation criterion that indicates construction quality. The building project manager and the specifier may define together specific requirements to improve the final construction.



## SAINT-GOBAIN PAM's solutions

Vibrations transmitted to the building structure are dampened by installing "sound absorbers" and by combining:

- couplings equipped with elastomer sealing gaskets which reduce metal to metal contact and prevent the transmission of vibrations.
- if required, rubber lined insulating brackets or acoustic dampeners, and stack supports equipped with elastomer gaskets.

In 2008, SAINT-GOBAIN PAM commissioned a series of comparative tests on airborne and structure-borne noises in installation conditions described by standard EN 14366, at the Fraunhofer Institute for Building Physics in Stuttgart.

*As all waste water pipe systems manufacturers apply the standard test protocol, it allows building project managers to compare their results.*

## Test results for the PAM pipe systems, in accordance with standard EN 14366.

	Flow rate l/s	Airborne noise			Structure-borne noise		
		2	4	8	2	4	8
SMU	Plain steel brackets	47	50	54	26	31	34
	Anti-vibration brackets	48	51	53	19	24	32
	Plain steel brckts + PAM Acoustic	48	50	54	5	11	19
ENSIGN	Ductile iron brackets	45	48	54	27	32	34
	Ductile iron brckts + PAM Acoustic	45	47	54	5	11	19

\* test results for 100 mm diameter.

## FOCUS

### PAM Acoustic: acoustic dampener

The acoustic dampener is designed to reduce structure-borne noise propagating through connections between the pipe system and the building.

This accessory, made of a stainless steel casing surrounding an elastomer shock absorber, is fitted between the back of the bracket and the structure (wall, ceiling, etc...).

It can be used on any cast iron pipe brackets whatever their diameter, from DN 40 to DN 150, installed horizontally or vertically.



**Airborne or structure-borne noise: All installations with brackets supplied by SAINT-GOBAIN PAM meet the common requirements of applicable standards.**

**In the event of special requirements, the PAM Acoustic dampeners used with plain brackets give outstanding results far exceeding usual target performances.**

In addition to the acoustic properties of the pipe systems and their accessories, the results obtained may be affected by a number of factors: nature of the partition walls or slabs sealing. To provide clear guidance, SAINT-GOBAIN PAM has carried out additional tests more in conformity with known sites practices: open hopper or not, changes in the partitions densities.

A complete report is available on request

# Environment

**100% recyclable indefinitely without losing any of its properties**

Cast iron is made from recycled raw materials and so saves natural resources. Unlike plastics, it can be completely and systematically recycled at the end of its life through processes that are not harmful to the environment.

PAM pipe systems can be recycled without any deterioration of their properties, so they can be reused for exactly the same purpose. In other words, a pipe can be recycled as pipe.

Owing to the stability of their mechanical properties, it is currently considered that the service life of PAM cast iron pipe systems is twice that of alternative products made of plastic materials.



## Nothing is wasted: everything is recycled

Cast iron pipe systems are based on the principle of modular ranges of removable components. Their mechanical assemblies are reversible. You can change your mind today or even tomorrow.

When pipe systems are disassembled or modified, these components can be reused, which cuts down waste dumping.



## Environmental Product Declaration

To help customers make a better-informed choice, SAINT-GOBAIN PAM published in 2006 an updated Environmental Product Declaration (FDES: Fiche de Déclaration Environnementale et Sanitaire) for its waste water and rainwater ranges.

In response to a worldwide need for harmonisation, the international standard ISO 21930 provides the principles and requirements for environmental declarations (EPD) of building products. This standard retains the complete life cycle of products "from the cradle to the grave" as the relevant analysis.

As the French standard was even more demanding, it was decided to keep this information model as described in the French standard NF P 01 010: objective analysis of the life cycle "from the cradle to the grave" and energy consumption with reference to a functional unit (UF)\*.

Some figures for the PAM pipework:

At production stage, cast iron, supposedly energy consuming, actually consumes:

- **1,94 Mj of total primary energy / UF**

As a reminder: yearly energy consumption for a family of three living in a 65 sqm flat = Primary Energy= 62382.5 Mj

- **118g of CO2 / UF** = reference emission target adopted by the European Union for a new motor vehicle.

- **10 litres of water from all sources/ UF**

Average daily individual water consumption in developed countries= 150 l

It should be noted that most of the water consumed is process cooling water which is discharged back to the natural environment without any treatment being required.

\* 1 ml = ratio including all the necessary components to make the pipe system required to collect and drain waste water and rainwater in a 4-storey building over a period of one year".

**FOCUS**



## Enhancing processes and optimising ease of installation

At design stage, the aims are to make the cast iron products lighter and easier to install on work sites and to improve installers' safety.

With the objective of reducing the impact on the environment, automation and inspections are increased in number in order to cut down on the consumption of raw materials and energy required whilst optimising product quality.

As a result of continued improvements in the spinning process, the profile and the weight of cast iron pipes have been optimised over the last 20 years while maintaining their robustness.

**10 kg less to carry for a diameter of DN 100 means greater productivity on work sites.**

## A manufacturer's commitment: protect the environment and the health of personnel

For SAINT-GOBAIN, commitment to sustainable development actions by ensuring their plants' absolute compliance with regulations in force is just the start.

The plants in the metallurgical industry call for greater vigilance and strict compliance with instructions as the risks of serious accidents are particularly high.

European cast iron plants have introduced an Environment Management System.

The comprehensive approach adopted led to the ISO 14001 certification for the Telford plant in the UK in 2004, and to the same certification covering product development for the Bayard plant in France, end of 2006.

As the world leader in construction products, SAINT-GOBAIN aims to provide innovative solutions to take up the challenges for the future posed by environment protection and energy savings.

All its products are designed with a view to making full allowance for environmental issues and enhancing the energy efficiency of buildings.

The Group is committed to protecting the health and safety of its employees, preventing its processes from having any detrimental environmental consequences, and fully integrating all the social and societal aspects of its operations into its business management.

Its adoption of the United Nations' World Pact in 2003 confirmed its commitment to responsible and sustainable development, as Saint-Gobain undertook to implement the pact's 10 principles as part of its strategy and its daily actions.



# EPAMS® stimulate your networks

A modern technique based on a dynamic principle

Traditionally, the rainwater is collected from a building roof at regular points, by gravity flow. The larger the roof area is the more numerous the points are. In the alternative method, called “syphonic”, the run-off water is drained in pipeworks operating at full bore, harnessing the principle of mechanical energy conservation between high spots, the rainwater outlets, and a low spot which is the main drain.

The EPAMS® system is a combination of anti-vortex outlets preventing air entering the pipework and cast iron SMU / ENSIGN pipe system. You can thus benefit from the technical reliability of cast iron for this specific application.

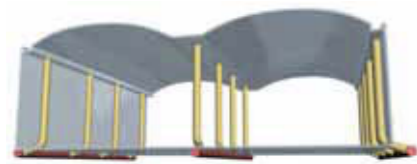

Gravity flow drainage

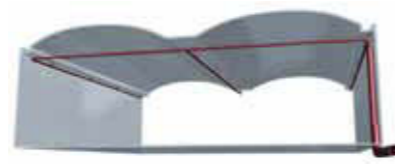

Syphonic drainage system

## Field of use.

Syphonic rainwater drainage system EPAMS® is devoted to drain run-off water from building roofs. It is particularly adapted to drain large roofs and minimize risks of overloading: Logistic building, commercial buildings, public buildings like stadiums or airports.\*

Or, for roofs in high rise buildings.

*\*when the type of roof is covered by the Technical Approval.*

## Operation and economy of a syphonic drainage system

In case of intense rainfall, the rainwater flows towards the outlet equipped with an anti-vortex mechanism. When the grid is half covered by rainwater -30mm- the mechanism limits the entering of air into the pipe system and initiates negative pressure.



As the speed and the water flow still increase the air entering the system decreases; it creates suction of the water into the roof outlets. When no air is entering the pipework, the drainage capacity of the syphonic system is at its optimum level.

An EPAMS® pipework consists of one or several horizontal pipes installed with no slope, connected to a downpipe.

At the bottom of the downpipe, the pipework is increased by generally two diameter sizes – causing decompression and reduction in the flow velocity. Before connection to the main drain the system returns to gravity flow.

Compared to a gravity flow system, syphonic drainage system allows long sections of horizontal small diameter pipes with no slope. The syphonic system has a greater compactness and save useable square meters. The global cost of a syphonic drainage system and a gravity flow are differently apportioned but a syphonic project has the ability to save below ground pipeworks.



## Syphonic safety over gravity flow

To harness the potential energy of the water drained in the pipework, in total safety, the syphonic system has to be accurately dimensioned. It must be designed by precise rules so that the flow velocity is always under control and the pressures within the pipework are always balanced. Furthermore, to protect the lifespan of the EPAMS syphonic pipe systems, SAINT-GOBAIN PAM design fixes that the dynamic pressure within the system should never exceed 5 bar.



### EPAMS® syphonic system: a reliable solution for total safety.

- At full bore, a syphonic system operation calls for resistance to negative pressure. The mechanical properties of cast iron and their stability allow the use of even smaller diameters for pipes, for a greater compactness and higher drainage capacity. Specific care was brought to the design of outlets to enhance their absorbing capacity and prevent any risks of roof overloading. EPAMS® all metal system is stable and serviceable in total safety, in the long term.

- The thorough management of the EPAMS® projects - feasibility study, project follow-up – is made to ensure the system efficiency and guarantee the project manager with total peace of mind.

The system safety lies in the accuracy of the design study, the system installation and the full respect by the building operator of maintenance requirements.

*All these arrangements have allowed the EPAMS® system registering no claim for the past 12 years it has been sold.*

*The EPAMS® system is run by a Technical Approval (14+5/01-656 and add-on 14+5/01-656\*01 Add), and undergoes precise controls.*

## EPAMS®: rely on the outstanding properties of the PAM cast iron systems.

Cast iron properties – mechanical strength and stability, thermal expansion coefficient, resistance to negative pressure, acoustic properties, resistance to fire and outstanding service life – make the EPAMS® system the best choice to design a safe and reliable syphonic system.

When feasibility is confirmed, a technical team designs both technical study and networks sizing. People specifically in charge with your project will remain at your disposal till the acceptance of work. Their knowledge of the system will allow them the find the best solution for your drainage project.



## Rigor and professionalism.

SAINT-GOBAIN PAM salesmen, trained to the EPAMS® system are at your service to evaluate your roof drainage project.

The installation of the EPAMS® system is generally performed by installers trained to our products. The traditional assembly at work progress allows to thoroughly cope with the reality and constraints of the job site, so that 100% of the expected performances are effectively achieved. SAINT-GOBAIN PAM is liable for the technical studies carried out. Before the acceptance of work, it delegates a staffer or third party control office on site, to check that the installation fully meets the last study.

**A certificate of technical compliance is delivered, after this pre-acceptance control.**

## Total cost of ownership

### The cost of failure

Building projects should always be considered as a whole. In most developed countries, building trade represents 40% of energy consumption and more likely, in coming years, managers will prioritise conservation of properties and favour refurbishment.

It is accepted that cast iron drainage systems are least likely to fail in any situation. In order to establish which materials are most appropriate, consider first the relative seriousness of the consequences arising from failure: disturbance, hygiene and noise issues.

### Product cost and installation costs

Cast iron is certainly not the cheapest material when considered initially and compared to other materials. However PAM cast iron means:

- **Quick traditional installation** with mechanical or push-fit couplings assembled with simple tools, without gluing or welding, **can save time and labour cost.**
- **No expansion joints** and therefore eases design and save expensive thermal limiters.
- **No systematic fire protection** or fire collars due to its fire behaviour
- **Less protection for acoustic insulation** due to its acoustic properties, and therefore means savings in plasterboards to reach the same performance.
- **Less embedment than other materials** in buried applications where ground disturbance or extra loading is likely.



**SAINT-GOBAIN PAM cast iron drainage systems combining**  
**More safety:** fire protection, pressure resistance  
**More comfort:** acoustic properties  
**More flexibility:** possible extensions or retro-fit  
**Fully meeting environmental and sanitary requirements,**  
**should lead you to move from the lowest tenderer to the lowest responsible bidder who selects the best quality- price ratio for the service life of the building.**

### Durability and less maintenance:

Cast iron has a proven lifespan far exceeding 50 years due to its outstanding mechanical properties and safety margin in operation.

- SAINT-GOBAIN PAM is continuously carrying out research on its coatings to protect this lifespan.
- PAM cast iron in exposed sections of the drainage system, ie. basement car parks is **more resistant to damage** than other drainage materials. It is also less sensitive to cracks and breakage before installation.
- Cast iron below ground offers **greater resistance to ground movement**, and is less likely to fail in unfavourable conditions.
- PAM cast iron drainage **needs minimal maintenance** during the lifetime of the building in normal conditions and makes it the first choice for concealed, built-in or otherwise inaccessible systems where repair or maintenance would cause major inconvenience to the occupants.
- Where necessary, removable mechanical couplings make **repairs easier and cheaper** without cutting into the stack. An extensive range of access parts, provides **ease of maintenance** at vital points in the stack to relieve any blockages which may occur.



### PRODUCT CALATOGUE

SAINT-GOBAIN cast iron pipe systems SMU – ENSIGN S, SMU – ENSIGN Plus, SME socket system and EEZI-FIT socket fittings.

- Comprehensive spigot or socket ranges of pipes fittings and accessories
- Consistent performances for above ground and below ground drainage applications
- Ease of installation with mechanical assembly allowing adjustments onsite
- Easy versatile assembly - retro-fitting of additions or changes to soil stacks



# PAM SMU / ENSIGN®S

## PRODUCTS IDENTIFICATION

### Pipes

**PAM-SMU® S, above ground**

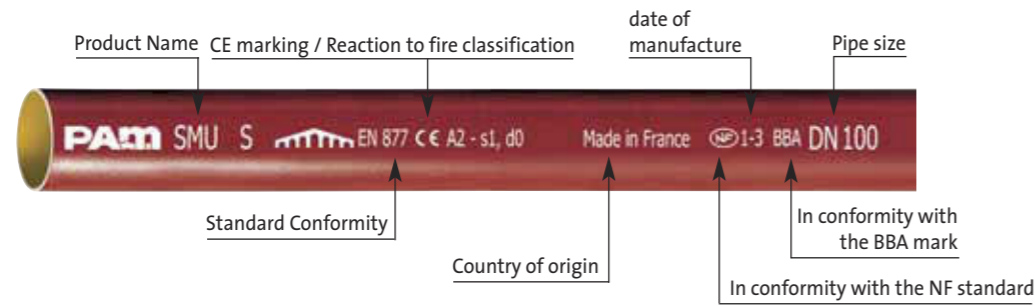

**PAM ENSIGN® S, above ground**

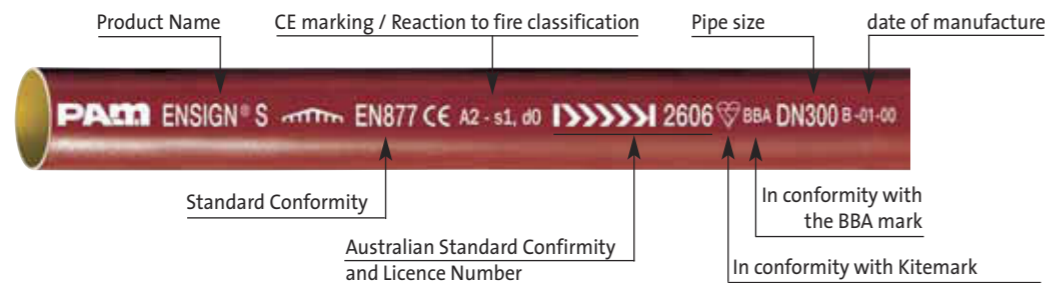

According to standard EN 877, pipes, fittings and accessories as well as the couplings or clamping components and the gaskets shall be legibly and indelibly marked and shall bear at least the following information:

- the manufacturer's name or mark
- the identification of the production site
- the period of manufacturing, coded or not
- the reference to this European standard
- the DN, or DN's where applicable
- the design angle of fittings
- the identification of the accredited third party where applicable

In the case of pipes the above markings shall be applied at least once per metre length.

### Fittings

The identification marking for Ensign fittings is a label.

**PAM-SMU® S**

**EN 877 =**  
In conformity with Standards  
**NF/BBA =**  
In conformity with Quality marks



**PAM-ENSGN® S**

**EN 877 =**  
In conformity with Standards  
**Kitemark/BBA =**  
In conformity with Quality marks



**CE Marking = A2 -s1, d0 (see p 22)**

# PAM SMU / ENSIGN®S

## PIPES

### Double spigot pipes (L= 3 m) - PAM SMU S



Pipe marking (example for a pipe of DN 300)

DN	DE*	Product code	Weight
50	58	156360	12.50
70	78	see Pam-ENSGN S	
75	83	156452	18.30
100	110	156560	24.30
125	135	156733	34.30
150	160	156824	40.90
200	210	156948	67.40
250	274	157047	97.30
300	326	157112	126.80
400	429	185193	177.70
500	532	185194	244.90
600	635	185195	321.90

\* External Diameter



Large diameters from DN 400 are now also available in 2.8 m length.

DN	DE*	Product code	Weight
400	429	216735	165.90
500	532	222513	228.60
600	635	222514	300.40

### Double spigot pipes (L= 3 m) - PAM ENSIGN S



Pipe marking (example for a pipe of DN 300)

DN	DE*	Product code	Weight
50	58	156363	13.00
70	78	156455	19.00
75	83	see Pam-SMU S	
100	110	156563	25.50
125	135	156736	35.50
150	160	156827	43.00
200	210	156951	69.30
250	274	157049	99.80
300	326	157114	129.70
400	431	See Pam-SMU S	
500	534	See Pam-SMU S	
600	637	See Pam-SMU S	

\* External Diameter



Large diameters from DN 400 are now also available in 2.8 m length.

DN	DE*	Product code	Weight
400	431	222665	165,90
500	534	222666	228,60
600	637	222667	300,40

### Pipes ends repair - EXTREM 1 - ONE COMPONENT

Red epoxy touch-up paint

Type	Product code
Tub 500 ml	226962
Tub 250 ml	226788

Where pipes are cut on site, ends shall be cut clean and square with burrs removed and then re-coated with the one component touch-up paint EXTREM 1.

Combining easy application and quick drying, this touch up paint is available in 250 ml and 500 ml tubs equipped with brush applicator cap. For indication, the 500 ml tub covers the repair of 75 DN100 cut ends (layer of average 0.5mm)

Weights are in kg

# PAM SMU / ENSIGN<sup>®</sup>S

## BENDS

### 15° Bends

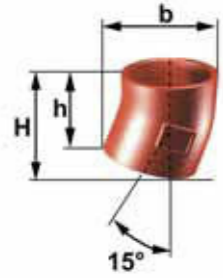

DN	Product code	b	H	h	Weight
50	155752	66	80	66	0.40
70	155781	88	98	78	0.60
75	176702	93	99	78	0.68
100	155816	121	112	83	1.00
125	155870	148	134	99	1.70
150	155903	173	148	108	2.50
200	155932	227	184	129	4.60

### 22° Bends

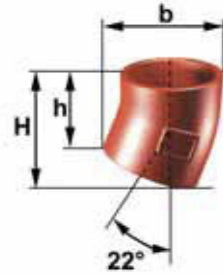

DN	Product code	b	H	h	Weight
50	156388	70	88	66	0.45
75	156480	97	105	74	0.80
100	156598	126	125	84	1.30
125	156761	152	143	92	1.85
150	156855	179	162	102	2.60
200	156974	233	200	122	4.40
250	157071	300	240	138	9.50
△ 300	157136	356	279	157	15.30

### 30° Bends

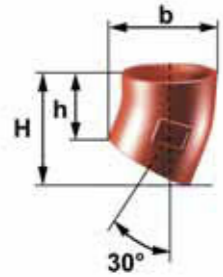

DN	Product code	b	H	h	Weight
50	155753	76	97	69	0.50
70	155782	97	112	73	0.70
75	176703	102	114	72,5	0.79
100	155817	132	136	81	1.30
125	155871	160	164	96	2.00
150	155904	189	188	108	3.00
200	155933	243	229	124	5.40
250	155948	309	270	133	9.70
300	155960	367	322	159	15.50

### 88° vented bends

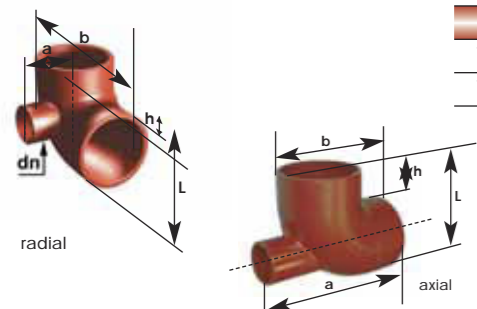

DN	dn	Ventilation	Product code	L	b	h	a	Weight
100	50	radial	157581	169	166	59	95	2.15
100	50	axial	156585	169	166	59	200	2.15

### 45° Bends

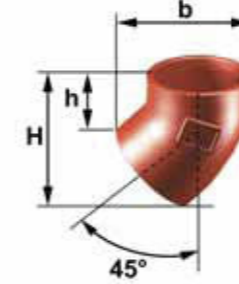

DN	Product code	b	H	h	Weight
50	156384	84	106	65	0.55
70	155780	108	129	74	0.90
75	156476	112	132	73	0.85
100	156593	142	158	80	1.57
125	156756	171	184	89	2.12
150	156850	199	210	97	3.19
200	156970	256	262	113	5.25
250	157069	324	319	125	10.00
300	157134	387	380	149	18.82
400	157175	540	573	270	34.34
△ 500	157190	678	730	350	64.00
△ 600	175540	788	821	370	93.00

### 68° Bends

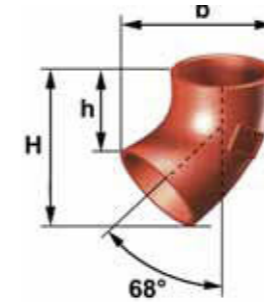

DN	Product code	b	H	h	Weight
50	156382	104	123	70	0.75
70	155779	123	139	67	1.10
75	156474	131	149	72	1.05
100	156591	159	176	74	1.80
125	156754	188	205	80	3.00
150	156847	219	237	89	4.10
200	156968	277	295	99	7.78
△ 250	157067	343	358	104	14.65
300	157132	406	423	121	20.00

### 88° Bends

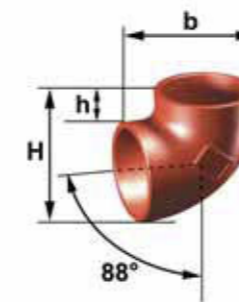

DN	Product code	b	H	h	Weight
50	156379	104	107	49	0.80
70	155778	130	132	54	1.40
75	156471	138	140	57	1.20
100	156588	166	169	59	2.22
125	156752	194	197	62	2.85
150	156844	227	230	70	4.34
200	156966	267	291	81	8.10
250	157065	360	363	89	13.50
300	157130	427	431	105	27.67

All dimensions are in mm and nominal weights in kg

△ On a quotational basis.  
 Obsolete pattern  
 See p 85 for details

# PAM SMU / ENSIGN®S

## BRANCHES

### 45° single branches

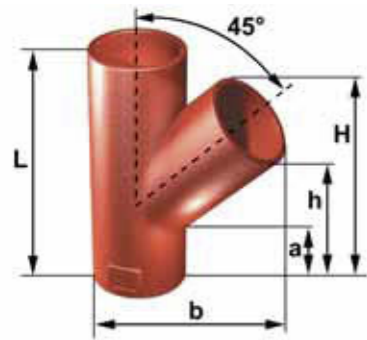

DN	dn	Product code	L	b	H	h	a	Weight
50	50	156435	185	144	165	124	36	1.15
70	50	155789	190	124	166	125	35	1.60
	70	155806	215	179	195	140	35	2.30
75	50	156490	180	156	161	120	43	1.80
	75	156544	215	179	198	140	40	2.35
100	50	156618	200	191	172	131	47	2.45
	70	155831	235	213	208	153	48	3.50
	75	156625	235	214	209	151	46	3.18
100	100	156701	275	238	253	175	45	3.95
	50	156769	205	218	170	130	44	3.24
	70	155879	240	236	208	153	49	4.30
125	75	156771	240	237	215	156	51	4.00
	100	156775	280	261	254	177	47	5.15
	125	156813	320	284	296	201	49	5.80
150	70	155910	245	259	208	154	52	5.60
	75	176733	255	265	220	161	54	5.10
	100	156879	295	287	262	185	54	6.10
	125	156883	325	307	298	202	52	7.30
150	150	156931	355	323	333	219	53	8.70
	70	155934	255	302	212	157	62	8.10
	75	176734	260	303	218	159	64	7.4
200	100	156982	310	340	275	198	67	9.33
	125	156984	340	360	310	215	64	10.69
	150	156989	375	383	353	240	66	12.32
	200	157030	455	418	428	280	68	15.80
250	100	157073	330	398	276	198	72	13.60
	125	157074	370	420	318	223	75	15.65
	150	157075	405	440	358	245	75	17.25
	200	157078	480	486	440	291	75	24.30
250	250	157106	580	537	530	335	70	32.80
	100	157138	350	445	287	208	88	19.30
	125	157139	360	464	316	221	80	20.00
	150	157140	415	487	359	246	81	23.20
	200	157141	485	547	454	305	81	28.40
250	250	157142	580	588	540	347	80	37.20
	300	157169	660	634	661	431	115	50.60
	300	157178	660	728	620	389	86	55.30
400	△400	157185	835	820	795	492	101	82.50
500	300	157193	720	861	680	448	114	86.00
600	300	157205	225	965	683	452	115	100.00

### 68° single branches

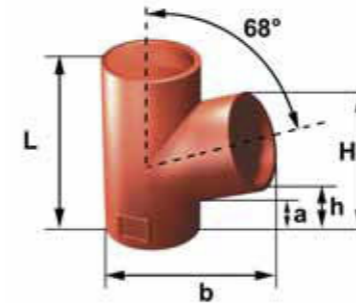

DN	dn	Product code	L	b	H	h	a	Weight
50	50	156433	145	118	117	65	37	1.10
70	50	155788	145	133	115	62	36	1.30
	70	155805	170	146	143	71	40	1.70
75	50	156488	155	140	122	69	42	1.40
	75	156542	180	158	149	72	37	2.35
100	50	156616	155	168	123	69	43	1.80
	70	155830	180	180	150	79	43	2.40
	75	156623	185	186	155	79	44	2.40
100	100	156699	220	195	189	87	50	2.95
	125	156773	225	222	190	88	50	3.80
125	125	156811	225	235	220	95	50	4.45
	100	156877	235	243	194	92	55	4.90
150	△125	156881	265	262	226	101	56	6.50
	150	156929	295	276	256	108	55	6.65
200	△150	156987	310	329	263	114	62	10.20
	200	157027	365	352	321	126	63	13.20
250	△200	157076	390	420	328	132	68	18.48
	△250	157104	460	452	408	154	77	20.10
300	300	157167	545	544	480	178	80	34.50

### 88° single branches

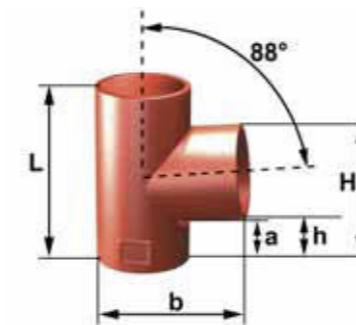

DN	dn	Product code	L	b	H	h	a	Weight
50	50	156431	145	110	111	53	31	1.10
70	50	155787	160	132	117	59	43	1.40
	70	155804	180	135	139	61	38	1.70
75	50	156486	160	132	117	59	42	1.50
	75	156538	180	138	140	57	37	1.95
100	50	156613	170	161	127	69	45	2.25
	70	155829	190	166	145	67	45	2.40
	75	156620	190	166	145	62	40	2.55
100	100	156695	220	172	174	64	41	2.65
	△50	156768	180	188	131	73	51	2.80
	70	155878	200	194	150	72	48	3.40
125	100	155880	235	199	184	74	48	4.00
	125	156809	260	205	209	74	48	4.50
	50	156870	200	221	134	76	51	3.90
150	70	155909	215	221	159	81	53	4.80
	75	156872	220	221	161	78	55	4.95
	100	156874	245	227	190	80	52	4.90
	125	155913	275	232	220	85	56	5.70
150	150	156925	300	237	243	83	55	6.50
	100	156980	270	282	206	96	64	9.80
	200	157024	365	388	296	86	67	11.10
250	250	157102	455	366	375	101	77	18.50
300	300	157165	530	433	437	111	87	34.00

All dimensions are in mm and nominal weights in kg

△ On a quotational basis.  
Obsolete pattern

# PAM SMU / ENSIGN®S

## BRANCHES

### 45° double branches

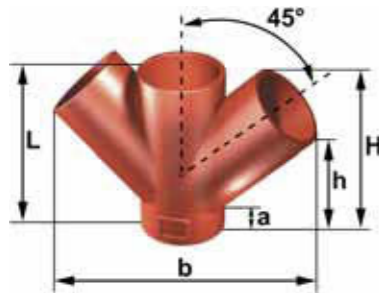

DN	dn	Product code	L	b	H	h	a	Weight
100	100	156709	260	346	243	165	46	4.5
125	125	156817	305	421	285	190	45	7.3
150	100	156865	280	394	252	174	54	7,3
	150	156936	355	488	334	277	55	11,7
200	200	157034	455	627	428	280	67	18,4

### 68° double branches

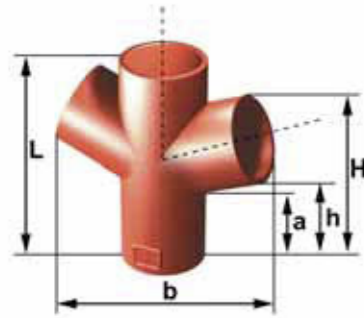

DN	dn	Product code	L	b	H	h	a	Weight
50	50	156437	145	178	118	64	35	1.30
75	50	156484	155	196	122	69	42	1.60
	75	156546	180	234	149	72	36	2.20
100	75	156609	185	262	155	79	44	3.00
	100	156707	220	281	189	87	50	3.90
125	100	156766	225	309	190	88	50	4.40
	125	156815	255	336	220	95	51	5.95
150	125	156867	265	364	226	101	56	5.80
	150	156934	295	392	256	108	57	8.10
200	150	156978	310	448	259	110	58	10.35
	200	157032	365	494	321	126	67	14.00

### 88° double branches

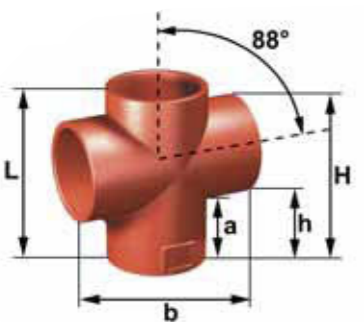

DN	dn	Product code	L	b	H	h	a	Weight
100	50	155825	170	212	127	69	45	2.20
	70	155826	190	222	145	67	44	2.70
	100	156704	230	243	179	69	49	3.20
125	100	155874	235	263	184	74	48	5.00
150	100	155907	245	294	190	80	52	7.10

### 45° corner branch

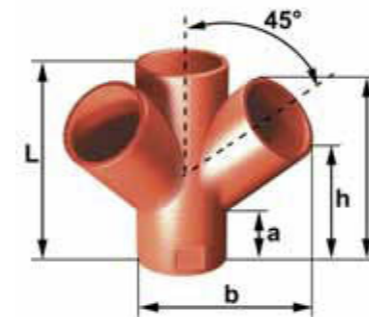

DN	dn	Product code	L	b	H	h	a	Weight
100	100	156716	260	227	242	166	46	5.20

### 68° corner branches

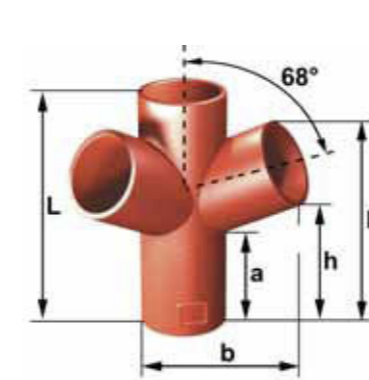

DN	dn	Product code	L	b	H	h	a	Weight
75	75	156548	180	158	149	72	36	2.30
100	100	156714	220	195	189	87	50	3.60

### 88° corner branches

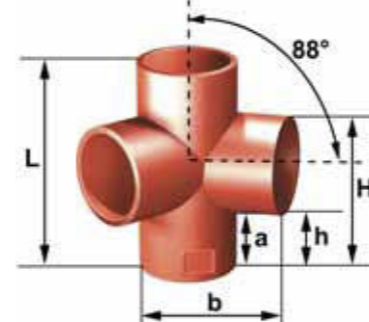

DN	dn	Product code	L	b	H	h	a	Weight
100	70	155839	190	166	145	67	44	2.70
	100	156712	230	177	179	69	44	3.40
125	70	155888	200	194	150	72	49	5.00
	100	155889	235	199	184	74	48	5.00
150	100	155919	245	227	190	80	52	7.10

All dimensions are in mm and nominal weights in kg

# PAM SMU / ENSIGN<sup>®</sup>S

## LONG FITTINGS

### 88° long radius bends

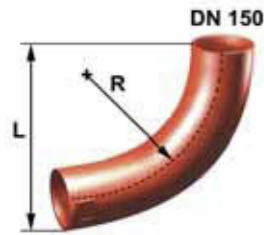

DN	Product code	L	R	Weight
100	156606	324	230	4.23
150	156860	349	210	8.00

At the base of soil and rainwater stacks, we recommend the use of long radius bends in order to enhance hydraulics and avoid deposits or blocking up.

### Offset bends 65, 75, 130, 150, 200 mm

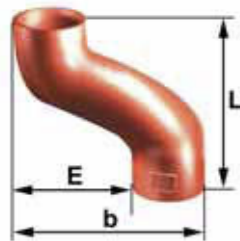

DN	Product code	L	b	E	Weight
50	△ 156386	185	133	75	1.09
	△ 156390	210	208	150	1.51
75	△ 156478	200	158	75	1.51
	△ 156482	230	233	150	2.32
100	△ 155812	205	175	65	2.30
	△ 156596	215	185	75	2.47
	△ 156602	270	240	130	3.65
125	△ 156604	250	260	150	3.32
	△ 155822	340	310	200	4.15
	△ 156759	236	210	75	3.67
150	△ 156764	270	285	150	4.80
	△ 156853	255	235	75	5.05
200	△ 156858	300	310	150	6.66
	△ 156972	295	285	75	8.30
	△ 156976	350	360	150	10.77

### 45° and 88° bends • Long tail

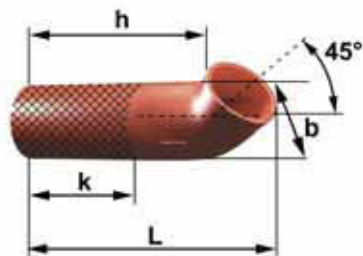

DN	Angle	Product code	L	b	h	k	Weight
△ 70	45°	155786	319	108	264	190	2.60
70	88°	155785	292	130	214	160	2.80
100	45°	155824	338	143	260	180	3.50
100	88°	155823	305	165	195	140	3.75

### 45° branch • Single long arm



DN	dn	Product code	L	b	h	a	Weight
100	100	156726	260	282	450	340	6.30

The single long arm 45° branch is specially used to connect to a downpipe when the space is limited. It is also used for wall penetration.

All dimensions are in mm and nominal weights in kg – k = maximum zone of possible cut

### 45° single branches • Long tail

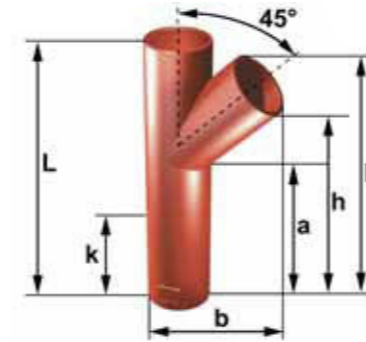

DN	dn	Product code	L	b	h	H	a	k	Weight
100	100	156723	430	238	346	424	241	170	5.50
△ 150	150	156938	705	323	571	684	403	350	18.48
△ 200	200	157036	770	423	600	749	383	320	28.00

### 68° single branches • Long tail

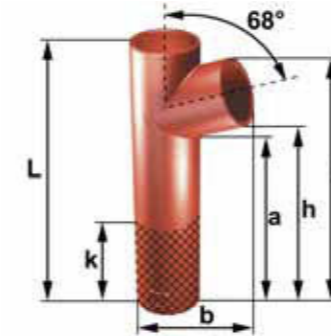

DN	dn	Product code	L	b	h	H	a	k	Weight
100	100	156721	460	195	328	430	290	250	5.20

### 88° single branch • Long tail

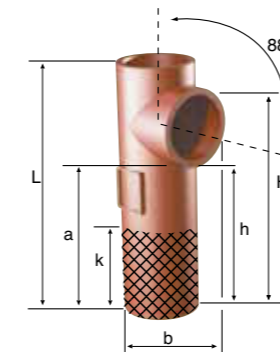

DN	dn	Product code	L	b	H	h	a	k	Weight
100	100	156720	430	177	379	269	244	210	4.80

### 88° corner branch • Long tail

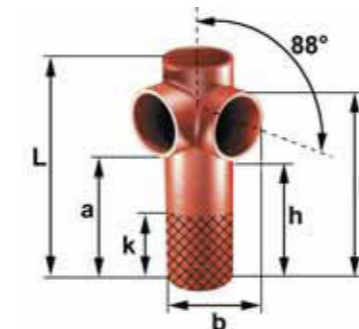

DN	dn	Product code	L	b	H	h	a	k	Weight
100	100	156725	430	177	379	269	244	210	5.33

△ On a quotational basis.  
Obsolete pattern

## CONNECTORS

### Blank Ends

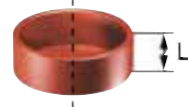

DN	Product code	L	Weight
50	156376	30	0.25
70	155776	35	0.40
75	156466	35	0.45
100	156581	40	0.80
125	156749	45	1.20
150	156841	50	1.70
200	156963	60	3.20
250	157062	70	5.90
300	157127	80	9.40

### Tapered pipes • Reducers

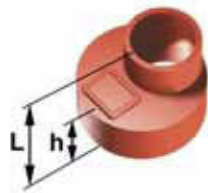

DN	dn	Product code	L	h	Weight
50	40	156354	75	40	0.30
70	50	155763	75	42	0.50
75	50	156424	80	47	0.70
100	50	156426	80	45	1.00
	70	155801	85	45	0.90
	75	156526	90	45	1.10
125	50	156428	85	50	1.50
	70	155802	90	50	1.50
	75	156528	95	52	1.30
150	100	156684	95	50	1.60
	50	156430	95	55	1.90
	70	155803	100	55	2.10
200	75	156530	100	57	1.70
	100	156686	105	60	2.30
	125	156805	110	60	1.95
250	75	156532	115	72	3.35
	100	156688	115	70	3.65
	125	156807	120	70	3.45
300	150	156919	125	65	3.85
	△ 75	156534	125	82	5.95
	100	156690	125	82	5.70
400	150	156921	135	82	5.90
	200	157020	145	80	6.10
	△ 75	156536	140	97	9.90
300	100	156692	140	95	9.10
	150	156923	150	97	9.70
	200	157022	160	95	9.70
250	157100	170	95	10.10	
300	157163	200	100	19.70	

△ On a quotational basis.  
Obsolete pattern

## ACCESS-FITTINGS / PLUGS

### Short access pipes

The access short access pipe combines reliability, ease of use and operation safety:

■ **Operation safety:**

Possible bleeding before opening in case of accidental overpressure = (1)

■ **Respect of the water stream and turbulence elimination:**

Shape of the elastomer plug inside = (3-4)

■ **Convenience:**

Ease of opening and closing the cast iron plug with standard tools or a T-handle operating wrench. Short access pipe are available for S and Plus ranges.

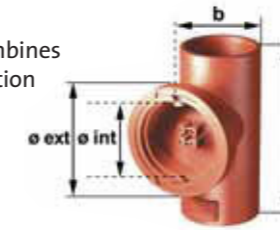

DN	Product code	L	b	Ø int	Ø ext	Weight
50	156414	160	102	75	108	1.90
70	155799	205	132	101	134	3.00
75	156513	205	132	101	134	3.00
100	156659	250	157	128	160	4.50
125	156794	280	192	154	189	6.50
150	156905	320	222	181	224	10.40
200	157015	360	270	181	224	12.75
250	157098	380	333	181	225	17.60
300	157161	400	385	181	227	26.30

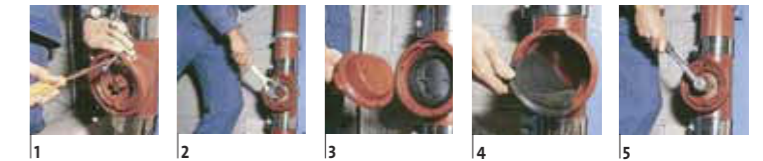

Short access pipe is also available for the Plus ranges  
See page 101 for information on resistance to accidental pressure

### Expansion plugs



Expansion plugs with bleeding valve are available on request for the 125/150 and DN 200 (for water tightness tests).

DN	DE	Product	L	H	Weight	Vis
50	62	156374	45	20	0.34	M8x50
70	85	156468	70	25	0.66	M8x50
75	90	156464	70	25	0.7	M8x50
75 SMA	80	226808	70	25	0.64	M8x50
100	118	156579	85	28	1.25	M8x60
125	143	156747	85	30	1.7	M8x60
150	168	156839	88	35	2.4	M10x60
200	220	156961	100	46	5.2	M10x70

See page 101 for information on resistance to accidental pressure

### Stack support pipes

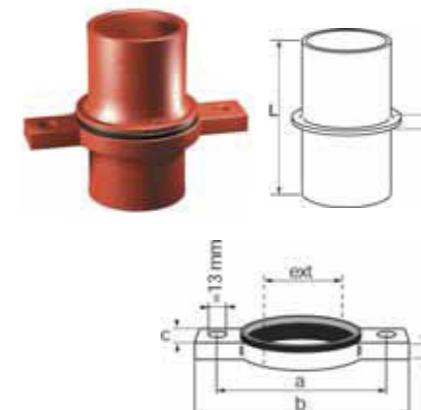

DN	Product code	L	a	b	c	d	e	Ø ext	Weight
50	156413	220	150	195	30	17	8	108	2.10
70	177742	200	170	215	30	19	8	128	2.00
75	156512	220	175	218	30	19	8	133	3.00
100	156657	220	214	259	32	20	8	162	4.50
125	156793	220	228	275	32	20	8	187	5.50
150	156904	220	255	300	32	22	8	222	7.20
200	157014	220	310	362	36	22	8	278	10.00
250	157097	300	394	444	40	25	8	354	18.50
300	157160	300	448	498	40	30	8	406	30.75

Weights are in kg

# PAM SMU / ENSIGN<sup>®</sup>S

## TRAPS AND VENTILATION

### Branch traps for rainwater systems

DN	Product code	L	b	h1	h2	a	c	e	H	Access(*)	Weight
50	156420	240	190	143	39	33	112	60	201	EP 50	2.90
70	156521	280	264	150	52	43	162	60	230	TS 50	5.48
75	156519	282	264	150	52	13	162	60	230	TS 50	5.85
100	156668	381	325	216	55	15	216	100	326	TS 50	9.50
125	156801	435	390	238	63	12	266	100	372	TS 75	13.10
150	156912	482	470	257	65	8	340	100	417	TS 125	21.80

DN	Product code	L	b	h1	h2	c	e	H	Weight
200	157018	590	600	300	80	415	100	510	26,60

(\*) Bottom access of cleaning: - EP by expansion plug  
- TS by tight sheet

**Dedicated to rainwater networks.**

The arrows stamped on the cast iron body show the flow direction

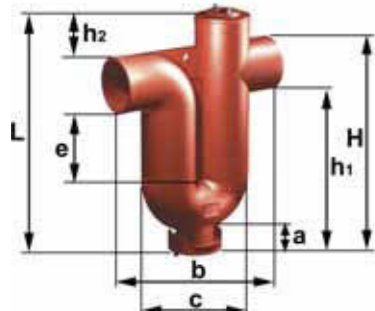

DN 50 to 150 trap

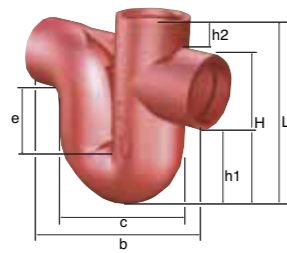

DN 200 trap

### Traps DN > 250: installation with 88° bends

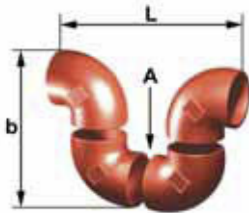

DN	L	b
250	900	725
300	1070	860

### Anti-Syphon Traps

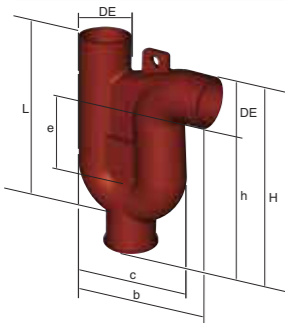

DN	DE	Product code	b	L	c	h	e	H	Weight
50	58	229107	165	262	-	187	80	245	2.75
75	83	156522	240	300	192	189	80	272	4.75
100	110	179013	316	382	255	240	80	350	9.20
150	160	156916	412	531	372	360	80	470	24.80

Special design for DN 50

Suitable for all waste water drainage systems, the Anti-Syphon Trap is particularly suited to systems without secondary ventilation. It ensures the retention of a water seal within the body of the trap to prevent odours

travelling backwards through the system and fouling the atmosphere around sinks, washbasins, baths, rainwater outlets etc. The Anti-Syphon Trap works by preventing the siphoning effect of a

heavy discharge through the system. It does this through the internal partition within the trap allowing the air to by-pass the water, thus breaking the vacuum created by the discharging water.

All dimensions are in mm and nominal weights in kg

### Vented Traps

DN	dn	Outlet	L	a	b	c	H	h	e	f	Total Weight
100	50	Vertical	177	373	571	343		218	223	238	8,81
100	50	Horizontal	177	373	405	343	271	218	113	238	6,55

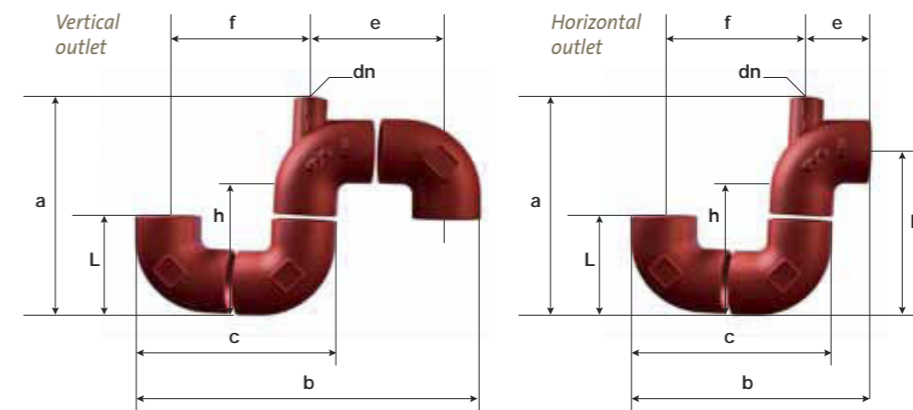

DN	dn	Product codes
100		156588
100	50	156585

### PAM ENSIGN<sup>®</sup>S Traps

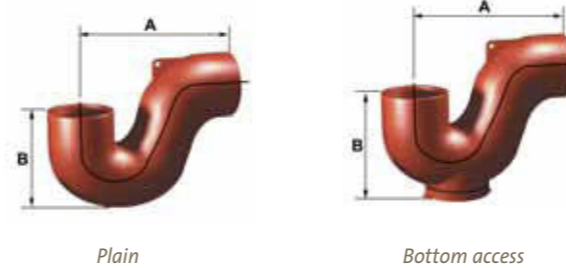

Plain

Bottom access

DN	Product code	A	B	Weight
Traps - Plain - EF034				
100	156666	255	160	1.80

DN	Product code	A	B	Weight
Traps - With access- EF037				
50	156419	160	115	2.00
70	156518	200	138	2.70
100	156667	255	175	5.20
150	156911	350	240	12.10

### Roof penetration: ductile iron flange fitting

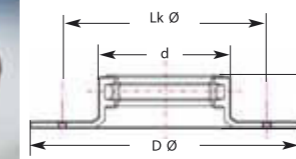

DN	Product code	D mm	d mm	Lk Ø mm	Weight kg
80	205922	286	135	215	6,1
100	205924	324	158	246	6,6
125	205925	349	188	271	7,5



Weights are in kg

DN	Product codes		Weight
EPDM gasket NBR gasket			
80	179894	179895	0.2
100	207320	207319	0.3
125	207335	207334	0.3

# PAM SMU / ENSIGN®S

## SPECIAL FITTINGS

### Branches for single downpipe 2 to 3 inlets • combined networks

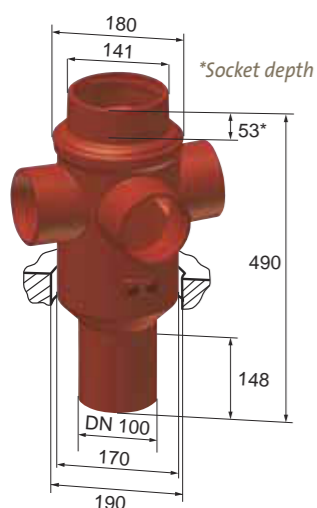

DN	Product code	Lateral adjustments	H	h	b	Weight
	△ 177237	3 consecutive DN at 88°				11.0
100	177236	2 DN at 88°	392	282	140	10.4
	177235	2 DN at 176°				10.8

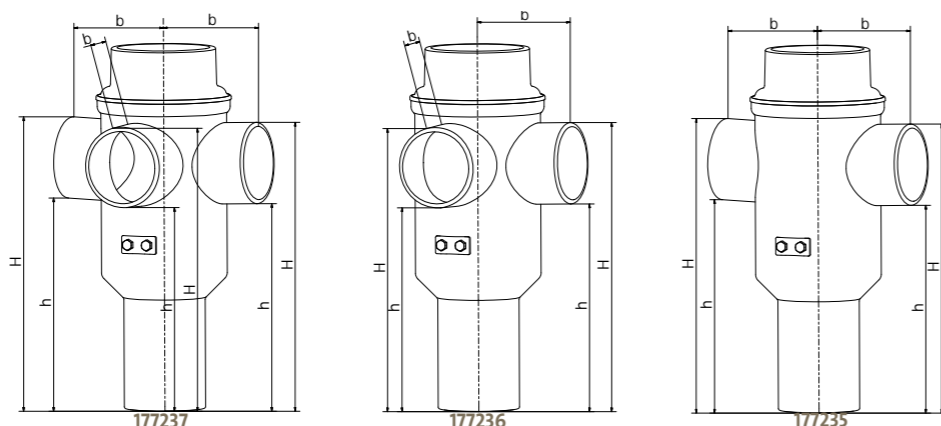

See P... for installation details

The branch for single downpipe allows wastewater drainage in a combined network without secondary ventilation according EN 12056. It simplifies plumbing by grouping pipework from 3 or 4 times more sources than a conventional installation. Maximum connexions for

each floor level:  
2 toilets, 2 bathtubs and all the usual sanitary facilities for two flats (sinks, basins, showers...)  
Particularly suitable for narrow service shafts, for hotel rooms, student flats or any other building with adjacent sanitary blocks

### PAM ENSIGN® Multi manifold

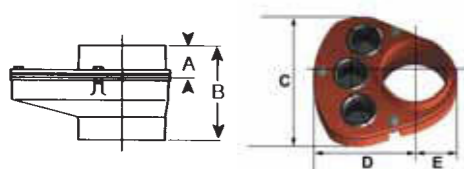

DN	Product code	B	C	D	E	Weight
<b>Manifold Connector - EF094</b>						
100	175626	43	125	200	142	3.20
150	175629	70	165	290	184	6.10

Replacement Plugs can be supplied on request

The multi-waste manifold simplifies waste plumbing by grouping all associated pipework from various

sources such as sinks, basins, bidets, urinals and showers to one internal point above the finished floor level.

See p 104 for installation details

### PAM ENSIGN®S 88° bends • Short and Long radius - Door back

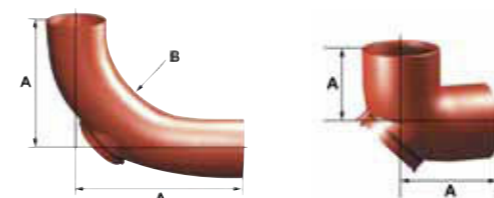

DN	Product code	A	Weight
<b>88° Bend - Short Radius Door Back - EF005</b>			
70	156472	90	1.80
100	156589	110	3.30
150	156845	145	6.10

DN	Product code	A	B	Weight
<b>88° Bend - Long Radius Door Back - EF05L</b>				
100	156607	269	180	1.80

### PAM ENSIGN®S 88° single branches • Radius curve



DN	Product code	A	B	C	Weight
<b>88° Single Branch - Radius Curve - EF06R</b>					
70x70	156539	210	80	130	2.20
100x50	156611	204	90	120	2.40
100x70	156612	221	90	142	2.70
100x100	156696	270	102	150	3.50
150x100	156869	300	117	202	7.60
150x150	156926	400	140	260	12.50
200x150	156985	428	157	283	13.00
200x200	157025	478	182	293	21.00

### PAM ENSIGN®S 88° branches with access • Radius curve



DN	Product code	A	B	C	Weight
<b>88° Branch with Access - Radius Curve - EF07R</b>					
△ 70x70	156540	210	80	130	2.50
△ 100x50	156614	204	90	120	2.40
△ 100x70	156621	221	90	142	3.50
100x100	156697	270	102	150	4.30
150x100	156875	300	117	202	10.40
150x150	156927	400	140	260	13.90

### PAM ENSIGN®S 88° double branches • Radius curve



DN	Product code	B	C	Weight
<b>88° Double Branch - Radius Curve - EF010R</b>				
100x100	157643	270	102	4.20
150x100	156862	300	115	10.90

All dimensions are in mm and nominal weights in kg

△ On a quotational basis.  
Obsolete pattern



## COMPENSATORS OF MOVEMENT

**Conditions of use:** Fittings intended to absorb the relative movement between two components of pipework; each one of its ends is fixed at 2 different elements of structure.

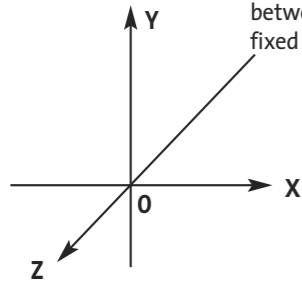

- L is the dimension of the compensator in neutral position. The maximum authorised movements following the three axis are noted:
- X axial movement
- Y vertical radial movement
- Z horizontal radial movement

Every reference is composed of:

- one movement absorber
- two bi-directional stack support pipes

Acceptable pressure for the DN 75 to 200:

- negative pressures up to - 0.9 bar
- positive pressures up to 3 bar (accidental and internal hydrostatic pressure)

### Compensators of movements for short range of movements

DN	DE	Product code	L	b	c	A	socket extension			Weight
							X	Y	Z	
△ 75	83	155050	895	81	139	218	± 30	± 30	± 30	18.4
△ 100	110	172638	897	80	140	250	± 30	± 30	± 30	20.80
△ 125	135	155067	897	80	140	275	± 30	± 30	± 30	26.00
△ 150	160	155072	909	78	142	300	± 30	± 30	± 30	29.30
△ 200	210	155077	932	78	142	362	± 30	± 30	± 30	40.40

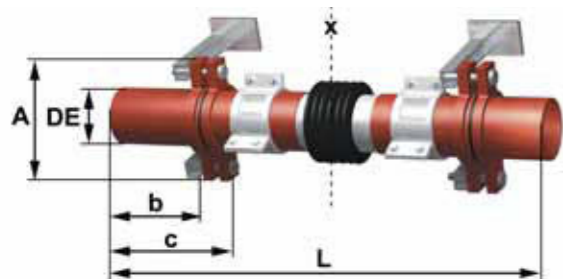

### Compensators of movements for long range of movements

DN	DE	Product code	L	b	c	A	socket extension			Weight
							X	Y	Z	
△ 75	83	155051	1794	81	139	174	± 60	± 130	± 130	25.60
△ 100	110	155063	1796	80	140	201	± 60	± 130	± 130	27.50
△ 125	135	155068	1796	80	140	227	± 60	± 130	± 130	33.00
△ 150	160	155073	1802	78	142	254	± 60	± 130	± 130	39.80
△ 200	210	155078	1824	78	142	306	± 60	± 130	± 130	55.60

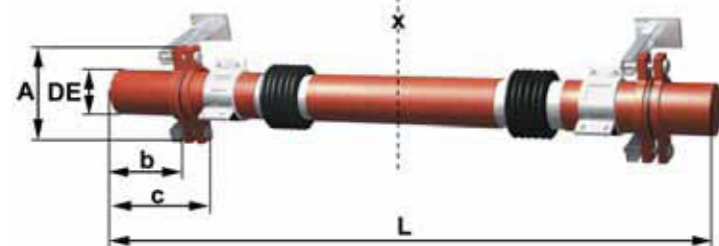

All dimensions are in mm and nominal weights in kg – k=maximum zone of possible

## SME / EEZI-FIT

### PUSH-FIT RANGES

SME and Eezi-fit ranges combine all the benefits of cast iron with the simplicity of push-fit assembly, completed in seconds.

**SME** socket pipes and fittings is a traditional range, available from DN 50 to 150. Particularly appreciated in sanitary renovation works or used as rainwater push-fit systems, the range enlarged over time to meet all site configurations, ease the installers work whilst respecting good practice. Complies with standard EN 877. The SME gaskets are supplied separately (see p 50).

**Ensign EEZI-FIT** is a new push-fit range of socket fittings and couplings in 100mm and now 150mm diameters, designed for above ground gravity sanitary applications. Particularly appreciated in new building projects, EEZI-FIT is fully compatible with all products within the SMU/Ensign range and is designed to meet product standard EN 877. The EEZI-FIT fittings are delivered with their gaskets.

#### Push-fit SME pipes

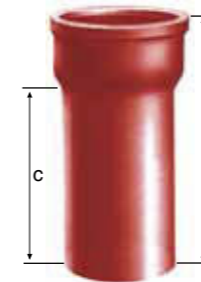

After pipe cutting operation, it is demanded to protect the face ends by applying a layer from the EXTREM 1 touch-up paint.

DN	DE	Product code	L	P	Weight
50	58	155170	3	62	13,7
		155169	2,5	62	11,6
		155168	2	62	9,5
		207351	1	62	4,7
75	83	155174	3	64	19,4
		155173	2,5	64	16,4
		155172	2	64	13,4
		207352	1	64	6,6
100	110	155180	3	66	26,3
		155179	2,5	66	22,2
		155178	2	66	18,2
		207353	1	66	9,1
125	135	155189	3	66	37,2
		155188	2,5	68	31,4
		155187	2	68	25,7
		207354	1	68	11,7
150	160	155193	3	70	44,3
		155192	2,5	70	37,5
		155191	2	70	30,8
		207355	1	70	14,3

#### 88° EEZI-FIT single branches

	DN	Product Code	A	B	C	D	E	F	G	Weight
Plain	100x100	208195	250	210	40	145	105	68	148	5.6
	150x100	216342	292	237	50	185	130	68	185	7.0
With access door	100x100	208197	250	210	40	145	105	68	148	6.7
	150x100	216314	292	237	50	185	130	68	185	8.0

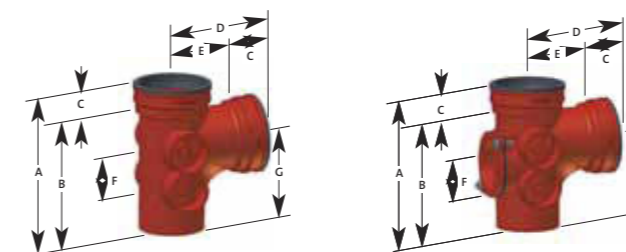

Weights are in kg

# SME range

## SOCKET FITTINGS

### SME "JC" rubber gasket



DN	Product code	Weight
50	156036	0,05
75	156077	0,07
100	156133	0,09
125	156187	0,11
150	156233	0,13

### SME "JL" rubber gasket for toilets



DN	Product code	Weight
75	156076	0,08
100	156132	0,13

### 45° Bends

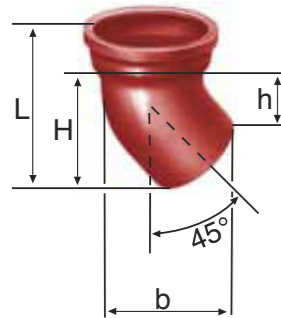

DN*	Product code	L	b	h	H	Weight
50	156033	184	116	120	79	1,3
75	156064	209	145	142	84	1,4
100	156111	226	169	159	81	2
125	156171	249	196	179	83	3
150	156022	273	224	201	88	4,2

### Slip fittings to accommodate building settlement



DN	Product code	P	a	Weight
50	156038	200	100	2,4
75	156079	200	100	3,3
100	156135	200	100	4,7
125	156189	200	105	6,3
150	156235	200	110	8,2

### 45° slip branch to accommodate building settlement

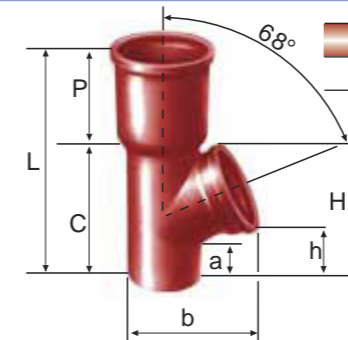

DN	dn	Product code	L	b	H	h	a	c	P	Weight
100	100	156011	350	230	248	113	76	210	140	5,40

### 45° simple branches

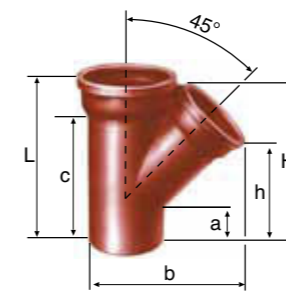

DN	dn	Product code	L	b	H	h	a	c	Weight
50	50	156053	265	184	246	182	201	77	2,68
75	50	155994	270	211	250	188	204	80	3,4
	75	156092	305	227	286	204	239	81	4
100	50	156007	265	232	247	183	197	81	4,36
	75	156129	305	252	286	205	237	85	5
125	100	156151	334	271	317	214	266	75	5,8
	100	156185	360	299	342	239	290	84	7,6
150	125	156019	400	331	377	255	330	78	9,25
	100	156227	370	326	346	243	298	93	9,56
150	125	156231	410	357	387	264	338	87	11,38
	150	156246	450	381	426	283	253	80	13,36

### 45° double branches

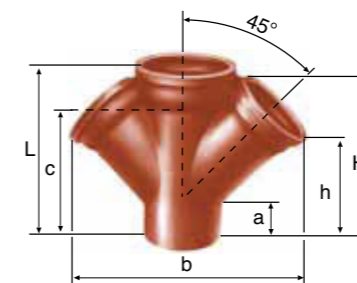

DN	dn	Product code	L	b	H	h	a	c	Weight
50	50	156057	265	310	246	182	200	77	3,65
75	50	156072	270	339	250	186	205	79	3,4
	75	156096	305	372	286	204	239	80	5,47
100	75	156125	305	393	287	205	237	85	6,32
	100	156155	370	463	347	244	302	90	8,54
125	100	156181	360	463	342	239	290	98	9,44
	125	156205	401	527	377	255	330	84	12,28
150	125	156223	410	554	387	265	338	92	14,32
	150	156250	450	602	426	283	378	90	17,6

### 45° simple branch • Long tail

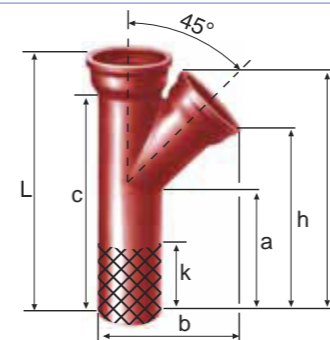

DN	dn	Product code	L	b	H	h	a	c	Weight
100	100	156015	510	287	487	384	230	442	154

Other shapes and angles available on request, please contact us.

# EEZI-FIT

## PUSH FIT FITTINGS AND COUPLINGS

### EEZI-FIT couplings

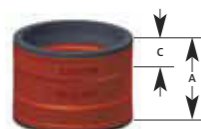

DN	Product code	A	C	Weight
100	208191	85	40	1.3
150	216312	114	55	2.0

Assembly instructions (see page 95). Gasket spare are available in bags of 10 – Product code 208204.

### 88° EEZI-FIT Bends • Short radius

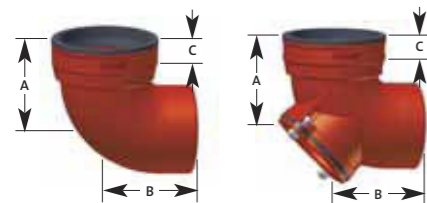

	DN	Product Code	A	B	C	Weight
Plain	100	208192	112	108	40	2.3
	150	216313	154	145	50	5.0
With access door	100	208194	112	108	40	3.4
	150	216315	154	145	50	5.7

### 88° EEZI-FIT Bends • Long radius

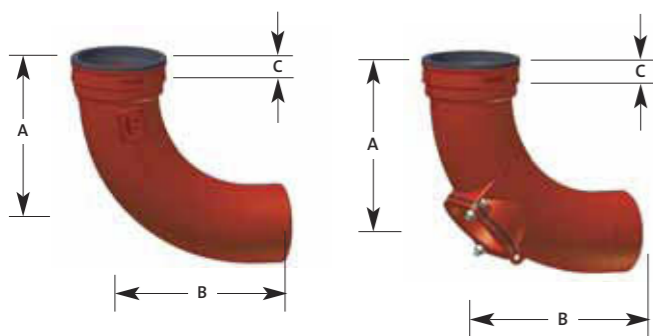

	DN	Product Code	A	B	C	Weight
Plain	100	215953	243	233	40	4.5
With access door	100	215952	243	233	40	5.6

### 88° EEZI-FIT double branch

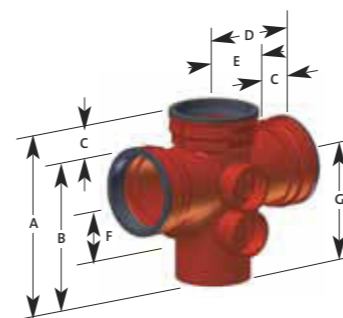

DN	Product code	A	B	C	D	E	F	G	Weight
100 x100	208198	250	210	40	145	105	68	148	6.0

If 45° double branch is required, use ENSIGN EF010 code 03009 with EEZI-FIT couplings. Rubber grommets to connect to 54mm OD copper or 56mm OD UPVC waste are supplied separately in bags of 10. (Product code 208205).

### EEZI-FIT single boss pipe 1 to 3 X 50 mm



	DN	Product Code	A	B	Weight
1 x 50 mm	100	208199	158	82	2.1
2 x 50 mm	100	208200	158	82	2.3
3 x 50 mm	100	208202	158	82	2.5

The boss pipes are supplied with rubber grommets to connect to 54mm OD copper or 56mm OD UPVC waste. For connections to 38/32 waste, use the reducers supplied by the manufacturers.

### EEZI-FIT manifold connector

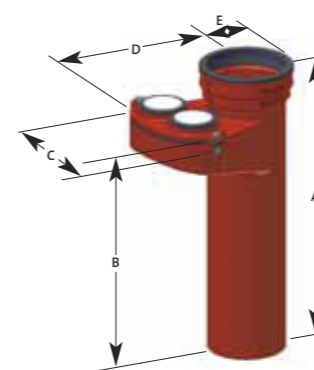

DN	Product code	A	B	C	D	E	Weight
100	208203	410	345	195	170	66	6.6

Supplied with rubber grommets to connect to 54mm OD copper or 56mm OD UPVC waste.

# PAM SMU / ENSIGN® Plus

## PRODUCTS IDENTIFICATION

### Pipes

#### PAM-SMU Plus,

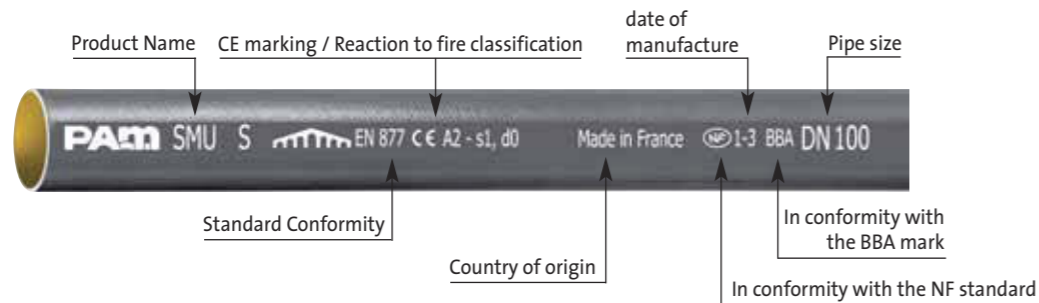

#### PAM ENSIGN® Plus,

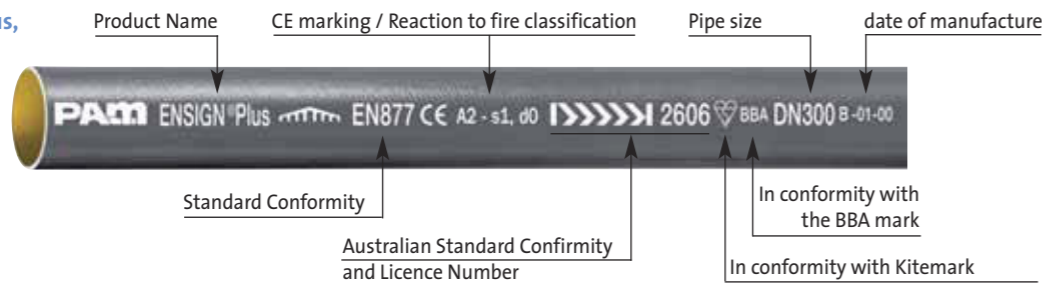

### Fittings

The identification marking for SMU / Ensign Plus fittings is a label.

#### PAM-SMU® Plus

EN 877 =  
In conformity with  
Standards  
NF/BBA =  
In conformity with  
Quality marks



#### PAM-ENSIGN® Plus

EN 877 =  
In conformity  
with Standards  
Kitemark/BBA =  
In conformity with  
Quality marks

CE Marking = A2 -s1, d0 (see p 22)

# PAM SMU / ENSIGN® Plus

### Double spigot pipes (L= 3 m - PAM-SMU® Plus



L = 3000 mm			
DN	DE*	Product code	Weight
△ 40	48	155296	9.00
50	58	155301	12.70
75	83	155320	18.50
100	110	155347	24.70
125	135	155390	34.80
150	160	155412	41.50
200	210	155446	68.20
250	274	155474	98.30
300	326	155491	128.10
400	429	185196	179.40
500	532	185197	247.00
600	635	185198	324.40

\* External diameter

DN	DE*	Product code	Weight
400	429	224507	167.40
500	532	224508	230.50
600	635	224509	302.80

Large diameters from DN 400 are now also available in 2.8 m length.

### Double spigot pipes (L= 3 m - PAM-ENSIGN® Plus



L = 3000 mm			
DN	DE*	Product code	Weight
100	110	155349	25.50
150	160	155414	42.70
200	210	155448	69.30
250	274	155476	99.80
300	326	155493	129.70
400	429	See Pam-SMU Plus	
500	532	See Pam-SMU Plus	
600	635	See Pam-SMU Plus	

\* External diameter

DN	DE*	Product code	Weight
400	431	222668	167.40
500	534	222669	230.50
600	637	222670	302.80

Large diameters from DN 400 are now also available in 2.8 m length.

### Pipes ends repair - EXTREM 1 - ONE COMPONENT

#### Grey epoxy touch-up paint

Type	Product code
Tub 500 ml	226962
Tub 250 ml	226788

△ On a quotational basis.  
Obsolete pattern

Where pipes are cut on site, ends shall be cut clean and square with burrs removed and then indispensably re-coated with the touch-up paint EXTREM 1. This one component product, red mat colour is available in 250 ml

and 500 ml tubs equipped with brush applicator cap. For indication, the 500 ml tub covers the repair of 75 DN100 cut ends (layer of average 0.5mm)

# PAM SMU / ENSIGN® Plus

## BENDS

### 15° Bends



DN	Product code	b	H	h	Weight
50	155202	66	89	66	0.40
70	155220	88	98	78	0.60
100	155237	121	112	83	1.00
125	155262	148	134	99	1.70
150	155278	227	148	108	2.50

### 22° Bends



DN	Product code	b	H	h	Weight
50	155308	70	88	66	0.46
75	155327	97	105	74	0.82
100	155358	126	125	84	1.33
125	155396	152	143	92	1.90
150	155421	179	162	102	2.67
200	155455	233	200	122	4.53
△ 250	155482	300	240	138	9.78
△ 300	155499	356	279	159	15.75

### 30° Bends



DN	Product code	b	H	h	Weight
50	155203	76	97	69	0.50
70	155221	97	112	73	0.70
100	155238	132	136	81	1.30
125	155263	160	164	96	2.00
150	155279	189	188	108	3.00

### 45° Bends

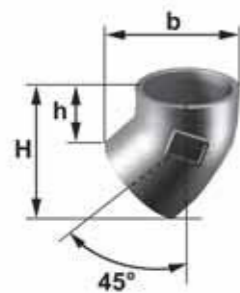

DN	Product code	b	H	h	Weight
50	155306	84	106	65	0.36
70	155219	108	129	74	0.90
75	155325	112	132	73	0.56
100	155356	142	158	80	0.87
125	155395	171	184	89	1.61
150	155420	199	210	97	2.18
200	155453	256	262	113	3.28
250	155481	324	319	125	5.40
300	155498	387	380	149	10.29
400	155509	540	573	270	18.82

### 68° Bends

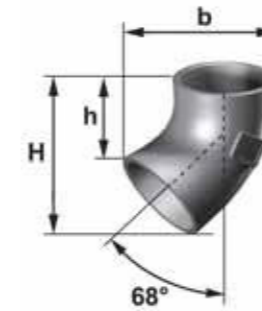

DN	Product code	b	H	h	Weight
△ 50	155305	104	123	70	0.77
△ 70	155218	123	139	67	1.10
△ 75	155324	131	149	72	1.08
100	155355	159	176	74	1.85
125	155394	188	205	80	3.08
150	155419	219	237	89	4.22
△ 200	155452	277	295	99	8.01
250	155480	343	358	104	15.08
300	155497	406	423	121	20.59

### 88° Bends



DN	Product code	b	H	h	Weight
50	155304	104	107	49	0.82
70	155217	130	132	54	1.20
75	155323	138	140	57	1.44
100	155353	166	169	59	2.28
125	155393	194	197	62	2.93
150	155418	227	230	70	4.43
200	155451	267	291	81	8.34
250	155479	360	363	89	13.90
△ 300	155496	427	431	105	28.49

All dimensions are in mm and nominal weights in kg

△ On a quotational basis.  
Obsolete pattern

# PAM SMU / ENSIGN® Plus

## BRANCHES

### 45° single branches

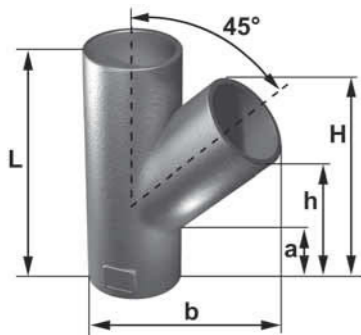

DN	dn	Product code	L	b	H	h	a	Weight
50	50	155316	185	144	165	124	36	1.18
70	50	155223	190	124	166	125	35	1.60
	70	155229	215	179	195	140	35	2.30
75	50	155331	180	156	161	120	43	1.85
	75	155344	215	179	198	140	40	2.42
100	50	155365	200	191	172	131	47	2.52
	70	155247	235	213	208	159	48	3.30
	75	155368	235	214	209	151	46	3.25
100	100	155380	275	238	253	175	45	4.06
	50	155398	205	218	170	130	44	3.33
	70	155265	240	236	208	153	49	4.30
125	100	155400	280	261	254	177	47	5.30
	125	155409	320	284	296	201	49	5.97
	70	155280	245	259	208	154	52	5.60
150	75	176785	255	265	220	161	54	5.10
	100	155430	295	287	262	185	54	6.28
	125	155432	325	307	298	202	52	7.51
	150	155442	355	323	333	219	53	8.95
200	70	155290	255	302	212	157	62	8.10
	100	155459	310	340	275	198	67	9.52
	125	155292	340	360	310	215	64	10.90
	150	155461	375	383	353	240	66	12.57
250	200	155470	455	418	428	280	68	16.26
	200	155483	480	486	440	291	75	25.02
250	250	155490	580	537	530	335	70	33.77
	250	155500	580	588	540	347	80	38.30
300	300	155507	660	634	661	431	115	52.10
	300	155510	660	728	620	389	86	56.94

### 68° single branches

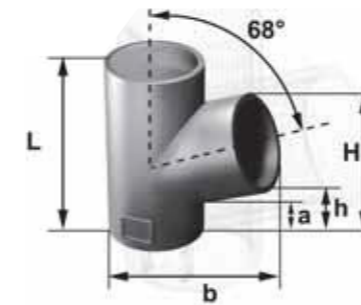

DN	dn	Product code	L	b	H	h	a	Weight
50	50	155315	145	188	118	65	37	1.13
75	50	155330	155	140	122	69	42	1.44
	75	155343	180	158	149	72	37	2.42
100	50	155364	155	168	123	69	43	1.85
	75	155367	185	186	155	79	44	2.47
100	100	155379	220	195	189	87	50	3.03
	125	155399	225	222	190	88	50	3.91
125	125	155408	255	235	220	95	50	4.58
	100	155429	235	243	194	92	55	5.04
150	125	155431	265	262	226	101	56	6.69
	150	155441	295	276	256	108	55	6.84

### 88° single branches

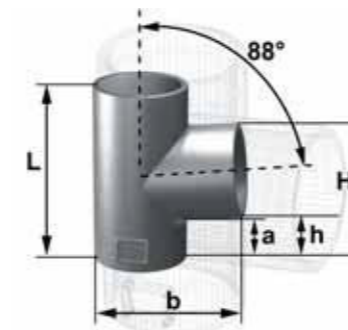

DN	dn	Product code	L	b	H	h	a	Weight
50	50	155314	145	110	111	53	31	1.13
70	50	155222	160	132	117	59	43	1.40
	70	155228	180	135	139	61	38	1.70
75	50	155329	160	132	117	59	42	1.54
	75	155342	180	138	140	57	37	2.00
100	50	155363	170	161	127	69	45	2.31
	70	155246	190	110	141	63	42	2.40
	75	176746	190	166	145	62	40	2.60
	100	115378	220	172	174	64	41	2.65
125	125	155407	260	205	209	74	48	4.58
	50	185472	200	221	134	76	51	3.90
150	75	155427	220	221	161	78	55	4.95
	100	155428	245	227	190	80	52	4.90
	150	155440	300	237	243	83	55	6.84
200	100	155457	270	282	206	96	66	8.80
	200	155468	365	288	296	86	67	7.41
250	250	155488	455	366	375	101	77	10.50
300	300	155505	530	433	437	111	87	13.59

All dimensions are in mm and nominal weights in kg

△ On a quotational basis.  
Obsolete pattern

# PAM SMU / ENSIGN® Plus

## BRANCHES

### 45° double branches

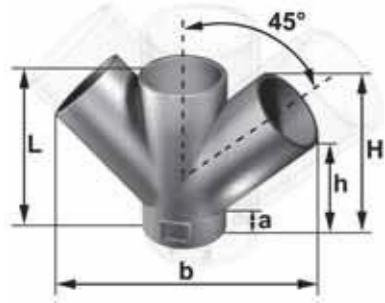

DN	dn	Product code	L	b	H	h	a	Weight
100	100	155384	260	346	243	165	46	4.63
125	125	155411	305	421	285	190	45	7.51
150	150	155445	355	488	334	277	55	12.04

### 68° double branches



DN	dn	Product code	L	b	H	h	a	Weight
△ 75	75	155345	180	234	149	72	36	2.26
△ 100	100	155383	220	281	189	87	50	4.01
△ 125	125	155410	255	336	220	95	51	6.12
△ 150	150	155444	295	392	256	108	55	8.34
△ 200	200	155472	365	494	321	126	67	14.41

### 88° double branch

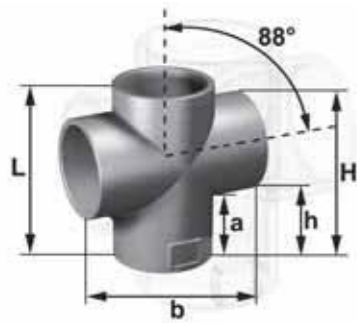

DN	dn	Product code	L	b	H	h	a	Weight
100	100	155382	230	243	179	69	49	3.29

### 45° corner branch

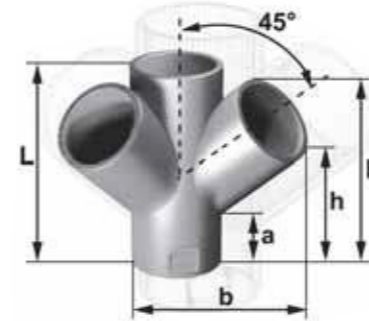

DN	dn	Product code	L	b	H	h	a	Weight
△ 100	100	155387	260	227	242	166	46	5.35

### 68° corner branches

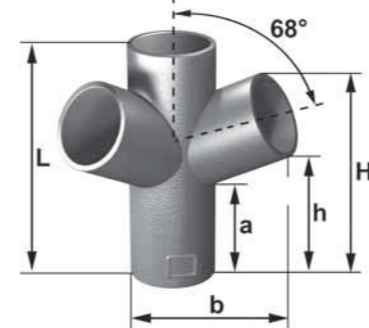

DN	dn	Product code	L	b	H	h	a	Weight
△ 75	75	155346	180	158	149	72	36	2.37
△ 100	100	155386	220	195	189	87	50	3.71

### 88° corner branch

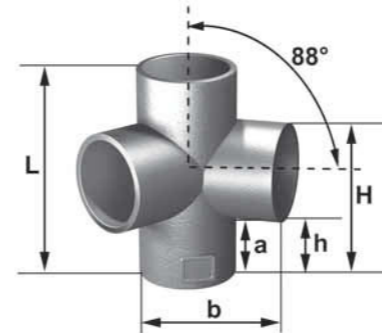

DN	dn	Product code	L	b	H	h	a	Weight
100	100	155385	230	177	179	69	44	3.4

All dimensions are in mm and nominal weights in kg

△ On a quotational basis.  
Obsolete pattern

# PAM SMU / ENSIGN® Plus

## BRANCHES/PLUG

### 45° single branches • Long tail

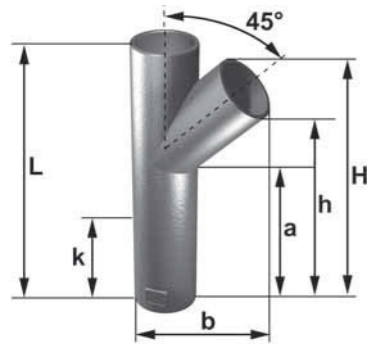

DN	dn	Product code	L	b	h	H	a	Weight
100	100	155381	430	238	346	424	241	5.71
150	150	155443	705	323	571	684	403	19.03
200	200	155471	770	423	600	749	383	28.83

### 68° single branch • Long tail

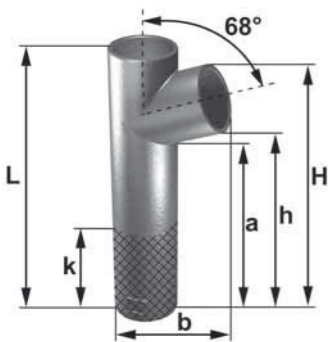

DN	dn	Product code	L	b	h	H	a	Weight
△ 100	100	155388	460	195	328	430	290	5.35

### Expansion plugs

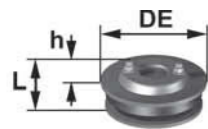

Expansion plugs with bleeding valve are available on request for the DN 100/150/200 and 300 mm (for water tightness test)  
See page 101 for information on resistance to accidental pressure

DN	DE	Product code	L	h	Weight	Screw
50	62	155303	45	20	0.34	M8x50
75	90	155322	70	25	0.7	M8x50
75 SMA	80	229477	70	25	0.64	M8x50
100	118	155351	85	28	1.25	M8x60
125	143	155392	85	30	1.7	M8x60
150	168	155417	88	35	2.4	M10x60
200	220	155450	100	46	5.2	M10x70

All dimensions are in mm and nominal weights in kg

## TRAPS/ACCESS PIPES

### Traps for rainwater drainage systems • Aggressive environments

DN	Product code	L	b	h1	h2	a	c	e	H	Access(*)	Weight
50	155311	240	190	143	39	33	112	60	201	EP 50	2.99
△ 70	155335	280	264	150	52	13	162	60	230	TS 50	5.00
75	155334	282	264	150	52	13	162	60	230	TS 50	6.02
100	155372	381	325	216	55	15	216	100	326	TS 50	9.78
125	155404	435	390	238	63	12	266	100	372	TS 75	13.49
150	155436	482	470	257	65	8	340	100	417	TS 125	22.40

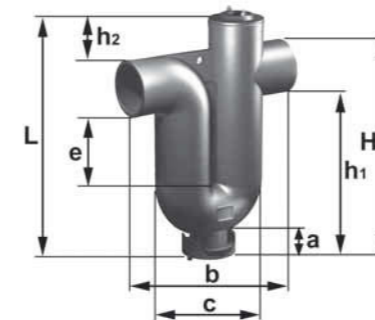

(\*) With cleaning access bottom.

Plus range trap DN 50 to 150

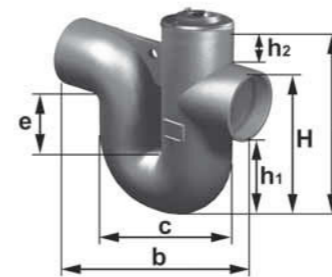

Plus range trap DN 200

DN	Product code	L	b	h1	h2	c	e	H	Weight
△ 200	155464	590	600	300	80	415	100	510	28.30

Dedicated to rainwater networks when subjected to aggressive environments.

### Short access pipes

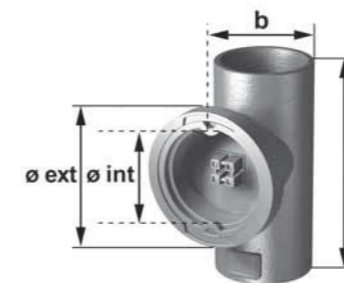

DN	Product code	L	b	Ø int	Ø ext	Weight
50	155310	160	102	75	108	2.01
75	155332	205	132	101	134	3.09
100	155370	250	157	128	160	4.63
125	155403	280	192	154	189	6.69
150	155435	320	222	181	224	10.71
200	155463	360	270	181	224	13.13
250	155486	380	333	181	225	18.12
△ 300	155503	400	385	181	227	27.08

See page 43 for information on opening and closing.  
See page 101 for information on resistance when accidental pressure.

△ On a quotational basis.  
Obsolete pattern



# PAM SMU / ENSIGN® Plus

## REDUCERS

### Tapered pipes

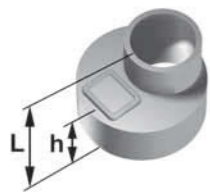

DN	dn	Product code	L	h	Weight
△ 40	50	155299	75	40	0.30
70	50	155208	75	42	0.50
75	50	155312	80	47	0.72
100	50	155313	80	45	1.03
	70	155225	85	45	0.90
125	75	155337	90	45	1.13
	△ 50	155210	85	50	1.54
	△ 70	155226	90	50	1.50
150	75	155338	95	52	1.33
	100	155374	95	50	1.64
	50	155211	95	55	1.95
	△ 70	155227	100	55	2.10
200	75	155339	100	57	1.75
	100	155375	105	60	2.36
	125	155405	110	60	2.00
250	△ 75	155340	115	72	3.45
	100	155376	115	70	3.75
	125	155406	120	70	3.55
	150	155439	125	65	3.96
300	75	155341	125	82	6.12
	△ 100	155377	125	82	5.86
	150	155437	135	82	6.07
400	200	155465	145	80	6.28
	△ 100	155373	140	97	9.37
	△ 150	155438	150	95	9.98
300	200	155466	160	95	9.98
	△ 250	155487	170	95	10.40
400	△ 300	155504	200	100	20.28

DN 500 and 600: do not hesitate to contact us

# PAM SMU / ENSIGN®

## COUPLINGS

### PAM CV-CE NG Couplings • New PAM design

These two bolts basic couplings are mostly appreciated because simple and easy to remove and reinstall without damage. The PAM design ensures better than ever water tightness and pressure resistance and noticeably improves corrosion resistance for these couplings.



DN	Product code		A	B	D <sub>≈</sub>	L	Weight
	CV	CE					
50	210398	185627	14	22.5	70	45	0,10
70	210400	207811	14	22.5	90	48	0,12
75	210413	207813	14	22.5	95	48	0,15
100	210416	185628	18	25.5	122	54	0,20
125	210417	207814	18	25.5	147	54	0,30
150	210418	207815	18	25.5	172	54	0,35
200	210420	207816	18	38	222	78	0,70
250	210422	207817	18	38	287	78	0,85
300	210423	185629	18	38	339	78	0,90

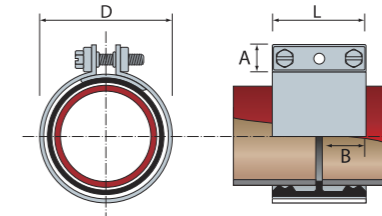

Tightening torques:  
 CV Couplings: 8-10 N•m for all DN  
 CE couplings: 5-8 N•m for DN 50-75/80  
 10-12 N•m for DN 100-125  
 12-15 N•m for DN 150-300

### Technical specifications:

#### CV couplings • standard version :

Collar : Ferritic Stainless Steel - 1.4510/11 or AISI 430Ti/439  
 Plates: Ferritic Stainless Steel – 1.4373 or 1.4510/11 or AISI 202 or AISI 430Ti/439  
 Screws: Coated Steel class 8.8 (minimum of 350 h/salt spray test)

#### CE coupling • all stainless steel version :

Identifying feature : W4  
 Collar: Austenitic Stainless Steel 1.4301 or AISI 304  
 Plates: Stainless Steel A2-70 or 1.4301 or AISI 304  
 Screws: Stainless Steel A2-70 with coating to avoid seizing

# PAM SMU / ENSIGN®

## COUPLINGS

### PAM RAPID NG couplings • New PAM design, unbeatable performance

The PAM Rapid NG coupling, single bolt, allows fast and reliable installation. SAINT GOBAIN PAM new design ensures optimized water-tightness and pressure resistance and better than ever corrosion resistance.



#### Standard version W2 technical specifications:

- Strap, clamps: 1.4510 /11 (AISI 430Ti / 439)

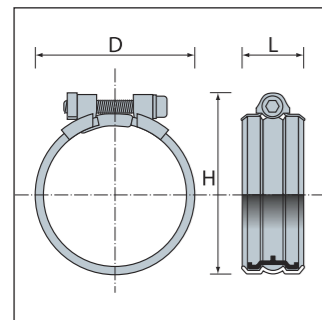

#### All stainless steel version W5 technical specifications:

- Strap, clamps: 1.4404 / 1.4571 (AISI 316 L/316Ti)
- Screw and nut: austenitic stainless steel A4-70 or AISI 316

The PAM Rapid NG is designed for a full tightening “nul gap”, there is no need for checking the torque.

For DN 250 and 300, apply the following torque: 25 N.m

### PAM RAPID-S NG couplings

DN	Product code W2 - S	D	H≈	L≈	Weight
50	210424	70	80	42	0.10
65 (75 SMA)	210824	83	94	42	0.12
70	210425	85	98	42	0.12
75/80	210426	90	103	42	0.12
100	210427	125	139	48	0.18
125	210428	147	161	56	0.28
150	210429	172	187	56	0.32
200	210430	223	240	70	0.60
250	228759	290	315	95	1.10
300	228771	350	375	95	1.25

### PAM Rapid NG • All stainless steel couplings

DN	Product code		D	H	L	Weight
	Stainless steel W5	W5 + NBR Gasket				
50	185635	212705	70	80	42	0.10
65 (75 SMA)	210823	212706	83	94	42	0.12
70	207818	212707	85	98	42	0.12
75/80	207819	212708	90	103	42	0.12
100	185636	212709	125	139	48	0.18
125	207820	212710	147	161	56	0.28
150	207831	212711	172	187	56	0.32
200	185637	212712	223	240	70	0.60
250	228773	212713	290	315	95	1.10
300	228775	212714	350	375	95	1.25

Recommended for pipe systems exposed to climatic stresses, i.e. rainwater spigot systems, drainage systems for bridges, or open multi-storey car parks.

### Specific offer for a complete Nitrile coupling.

For waste water liable to contain hot oil, solvents or hydrocarbons, it is recommended to use couplings equipped with specific NBR gaskets.

From now on, to meet these special requirements the PAM Rapid NG all stainless steel W5 coupling alone will be delivered with NBR gasket (complete product codes in the table above).

### PAM-SMU RAPID® 2 couplings

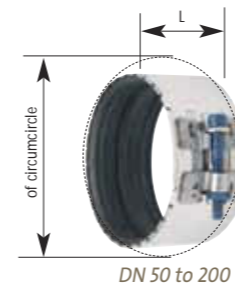

DN	Product Code EPDM	L	Ø of circumcircle	Weight
50	157635	51	104	0.14
75	157638	51	126	0.16
100	157641	58	160	0.22
125	157645	58	182	0.25
150	157648	58	206	0.28
200	157650	58	272	0.42

### PAM-SMU RAPID® 2 • All stainless steel couplings

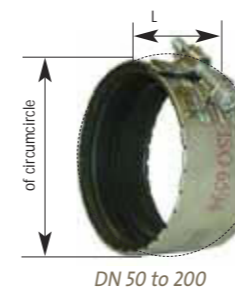

DN	Product Code EPDM**	L	Ø of circumcircle	Weight
50	157636	51	104	0.14
75	157639	51	126	0.16
100	157642	58	160	0.22
125	157646	58	182	0.25
150	157649	58	206	0.28
200	157651	58	272	0.42

\*\*For NBR gaskets see PAM Rapid NG W5 couplings + NBR product codes on previous page and table below.

# PAM SMU / ENSIGN®

## PAM GRIP COLLARS

Rainwater pipe systems or drainage pipe systems can undergo accidental overpressure due to overloading or to the saturation of the sewer main. In specific sections - changes of direction and gradient, branches and plugs - the leak tightness and the pipe work stability call for joints able to address end thrust efforts. Depending on the diameter and the pressure level targeted combinations of couplings and grip collars or self-anchored high pressure couplings can equally be used. Where couplings are used with grip collars, the pressure performance of the assembly is defined by the weaker of the two products.

Refer to the products specifications page 93.

### PAM grip collars

Designed by SAINT GOBAIN PAM, the PAM grip collar combines outstanding mechanical properties with very good pressure performance same as those of the PAM designed couplings, far over the Standard requirements.

The thorough selection of the steels also ensures a very good corrosion resistance.

This grip collar tightens "null gap", there is no use checking the torque.

#### Technical specifications

Frames : Galvanised steel  
Grips : Stainless steel + treatment  
Tightening plates : Galvanised steel  
Screws : Coated steel - class 8-8

### PAM grip collars for couplings



Totally versatile, the PAM grip collar is compatible with all the PAM designed couplings or of equivalent shape.

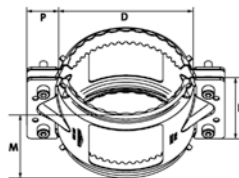

**Pressure resistance**  
DN 50-125: 10 bar  
DN 150 -200: 5 bar  
DN 250-300: 3 bar

DN	Product code	D ≈	P ≈	L ≈	M ≈	Wrench dim.	Weight
50	221261	88	22	72	76	6	0.45
70	221267	110	22	74	79	6	0.55
75 SMA	221266	110	22	74	79	6	0.54
75/80	221268	105	25	73	78	6	0.53
100	220750	145	33	88	93	6	0.90
125	221269	165	32	88	93	6	0.99
150	221270	196	32	96	102	6	1.23
200	221271	252	32	115	118	8	1.72
250	227039	318	38	131	140	8	2.25
300	227040	371	38	131	140	8	2.50

### PAM Grip collars for expansion plugs

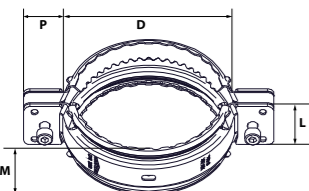

DN	Product code	D ≈	P ≈	L ≈	M ≈	Wrench dim.	Weight
50	222092	88	22	43	47	6	0.33
75 SMA	222093	110	22	43	47	6	0.42
70	222126	110	22	43	47	6	0.40
75/80	222127	105	25	41	47	6	0.40
100	221563	145	33	45	50	6	0.61
125	222129	165	32	49	54	6	0.71
150	222131	196	32	51	56	6	0.89
200	222133	252	32	60	64	8	1.2

**Pressure resistance**  
DN 50-125: 10 bar  
DN 150 -200: 5 bar

For DN 250 and DN 300 use plain plugs + couplings with PAM grip collars for couplings.

All dimensions are in mm and weights in kg. See p 90 for installation instructions and p 93 for grip collars and couplings compatibility.

### Griped High pressure couplings.

In sections where end thrust efforts have to be addressed, the autogrip couplings are alternative solutions to secure junctions whilst addressing pressure.

The PAM GRIP HP couplings are self-anchored couplings with built-in claw rings.

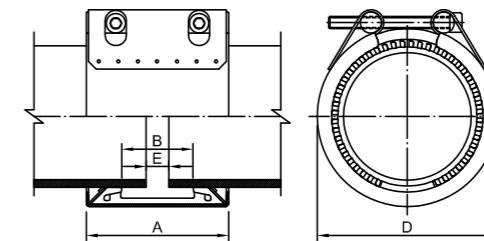

### GRIP HP COUPLINGS - S • All stainless steel

Type A2

Casing: 1.4307  
Screws: 1.4301  
Barrels: 1.4307  
Strengthening plate: 1.4307  
Grips: 1.4310  
Sealing gasket: EPDM

DN	EPDM	NBR	A mm	B mm	D mm	E mm	Pressure Resistance	Torque Nm	Wrench dim.	≈ Weight
100	227336	228705	94	45	133	15	10	20	6	1,3
125	227337	228706	95	45	158	15	10	20	8	1,9
150	227338	228707	95	45	183	15	10	30	8	2,1
200	227339	228708	141	60	251	35	10	50	10	5,3
250	227340	228709	141	60	305	35	10	65	10	8,7
300	227351	228710	141	60	356	35	10	80	10	9,9
400	227352	228721	141	60	438	35	6	80	10	11,7
500	227353	228722	142	60	557	35	3	80	10	12,8
600	227354	228723	144	60	660	35	2	120	10	14,1

### GRIP HP COUPLINGS - INOX • All stainless steel, superior quality

A4 Type:

Casing: 1.4404  
Screws: 1.4401  
Barrels: 1.4404  
Strengthening plate: 1.4404  
Grips: 1.4310  
Sealing gasket: EPDM

DN	Nouvelles refs	NBR	A mm	B mm	D mm	E mm	Pressure Resistance	Torque Nm	Wrench dim.	≈ Weight
100	227344	228724	94	45	133	15	10	20	6	1,3
125	227345	228725	95	45	158	15	10	20	8	1,9
150	227346	228726	95	45	183	15	10	30	8	2,1
200	227347	228727	141	60	251	35	10	30	10	5,3
250	227348	228728	141	60	305	35	10	50	10	8,7
300	227349	228729	141	60	356	35	10	80	10	9,9
400	227350	228730	141	60	438	35	10	90	10	11,7
500	227361	228731	142	60	557	35	6	90	10	12,8
600	227362	228732	144	60	660	35	4	80	10	14,1

# PAM SMU / ENSIGN®

## HIGH PRESSURE COUPLINGS

PAM-FLEX couplings are high pressure couplings. They can withstand up to 10 b of hydrostatic pressure for most diameters (see table below). These couplings are used for straight runs where these pressures can occur.

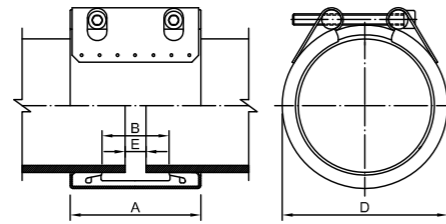

### HP COUPLINGS - S

Casing: 1.4307  
Screws: 1.4301  
Barrels: 1.4307  
Strengthening plate: 1.4307  
Sealing gaskets: EPDM

DN	EPDM	NBR	A mm	B mm	D mm	E mm	Pressure Resistance	Torque Nm	Wrench dim.	≈ Weight
100	228257	228684	94	45	129	15	10	10	6	1,4
125	228258	228685	94	45	152	15	10	10	6	1,5
150	228259	228686	94	45	180	15	10	10	8	1,7
200	228260	228687	139	86	229	35	10	20	8	3,8
250	228271	228688	139	86	294	35	10	25	8	4,3
300	228272	228689	139	86	346	35	10	25	8	4,7
400	226261	228690	139	86	449	35	6	25	8	7,1
500	226262	228691	139	86	551	35	3	30	8	6,7
600	228273	228692	139	86	653	35	2	35	8	7,6

### HP COUPLINGS - INOX • All stainless steel, superior quality

Casing: 1.4404  
Screws: 1.4401  
Barrels: 1.4404  
Strengthening plate: 1.4404  
Sealing gaskets: EPDM

DN	Nouvelles réfs	NBR	A mm	B mm	D mm	E mm	Pressure Resistance	Torque Nm	Wrench dim.	≈ Weight
100	228623	228693	94	45	129	15	10	10	6	1,4
125	228624	228694	94	45	152	15	10	10	6	1,5
150	228625	228695	94	45	180	15	10	10	8	1,7
200	228626	228696	139	86	229	35	10	20	8	3,8
250	228627	228697	139	86	294	35	10	25	8	4,3
300	228628	228698	139	86	346	35	10	25	8	4,7
400	228629	228699	139	86	449	35	10	25	8	7,1
500	228630	228700	139	86	551	35	6	30	8	6,7
600	228631	228701	139	86	653	35	4	35	8	7,6

Weights are in kg

# PAM SMU / ENSIGN® Plus

## PLAIN COUPLINGS, GRIP AND HP INOX COUPLINGS

Recommended products for below ground applications

### PAM Rapid NG W5 • All stainless steel



See page 66

### PAM CE NG • All stainless steel



See page 65

### HP and HP GRIP • All stainless steel



See page 70

### PAM-SMU Rapid 2® • All stainless steel



See page 67

## DUCTILE IRON COUPLINGS

Above ground

### Two piece ductile iron couplings

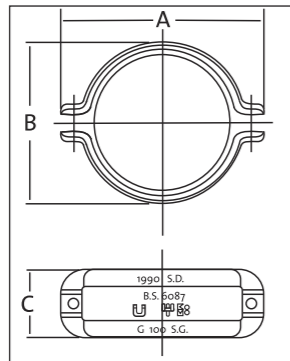

DN	Product code	A	B	C	Weight
<b>Two piece ductile iron coupling</b>					
50	156398	113	79	58	0.60
70	156493	129	103	58	0.60
100	156634	170	137	58	0.80
125	156777	188	158	58	0.90
150*	156888	217	183	80	1.70
200*	156998	278	243	82	3.50
250*	175552	343	308	82	4.40
300*	175510	395	360	82	5.40

\*150-300mm include 4 socket bolts.



Patent No. 2 305 481  
NBR gaskets will be considered on request, on a quotational basis.

With built-in electrical continuity

### Push Fit Joints (PFJ)

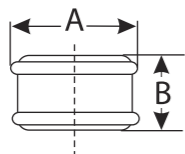

DN	Product code	A	B	Weight
<b>Joint - plain no ears</b>				
50	Consult us	99	73	0.90
70	Consult us	120	73	1.20
100	Consult us	152	73	1.80
150	Consult us	205	95	2.80

Registered Design  
No. 2 083 167



DN	Product code	A	B	C	D	E	Weight
<b>Joint - with fixing ears</b>							
50	Consult us	146	114	73	62	20	1.40
70	Consult us	178	146	73	71	20	1.90
100	Consult us	213	181	73	90	20	2.60
150	Consult us	273	235	95	115	20	3.60

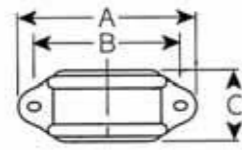
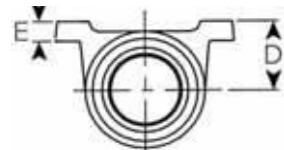

All dimensions are in mm and nominal weights in kg

Below ground

### Two-piece ductile iron couplings (Grey – ED001)



NBR gaskets will be considered on request, on a quotational basis.

DN	Product code	A	B	C	Weight
100	155369	170	137	58	0.80
150*	155433	217	183	80	1.70
200*	155462	278	243	82	3.50
250*	175591	343	308	82	4.40
300*	175592	395	360	82	5.40

\*150-300 mm incorporates 4 socket bolts.

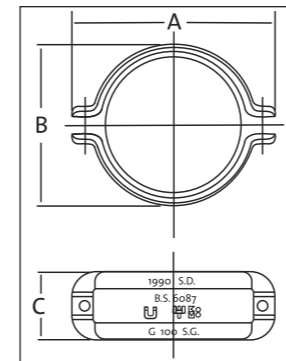

### Push fit sockets (Grey - ED004)



DN	Product code	A	B	Weight
100	175622	140	90	1.20
150	175623	195	95	2.20

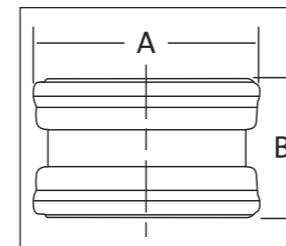

# PAM SMU / ENSIGN®

## CONNECTORS

### Stepping rings for connection to other materials

Use with a PAM-SMU® Rapid 2 or a PAM CV-CE



DN	Product code	DE*	Weight	Materials
50	156399	50	0.02	HDPE and PVC
75	156495	63	0.06	HDPE
75	156494	77	0.03	PVC
100	156555	91	0.10	HDPE
100	156635	100	0.05	PVC
125	156778	125	0.06	HDPE and PVC
200	157000	200	0.15	HDPE and PVC
250	157085	250	0.45	HDPE and PVC

### Adapting collar



DN	Product code	D mini	D maxi	L	Weight
75	155001	75	90	100	0.40
100	155002	100	115	100	0.70
100	TXB10NP01	110	121	120	0.70
125	TXB12NLOG	130	150	120	1.00
150	TXB15NMOJ	150	175	120	1.00
200	TXB20NLOK	200	225	150	1.50

### Adapting collar and stepping ring

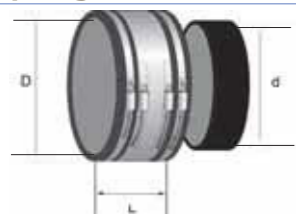

DN	Product code	D mini	D maxi	d mini	d maxi	L	Weight
200	TXB20NNOK	200	225	192	201	150	1.90

### Adapting joint

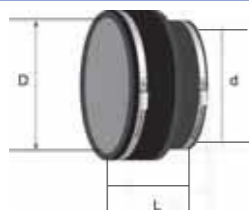

DN	Product code	D mini	D maxi	d mini	d maxi	L	Weight
150	155003	155	170	130	145	120	0.80
200	155004	170	193	210	235	150	1.50

### EPDM plugs: possible branch connection

EPDM plugs 1 or 2 inlets



EPDM plug 3 inlets



DN	Product code	1st aperture Ø in mm	2nd aperture Ø in mm	3rd aperture Ø in mm	Weight
<b>with stainless steel collar</b>					
50	156394	32 or 40			0,10
75	156492	(32 or 40) or (42 or 50)			0,18
100	156628	32 or 40	32		0,29
<b>without stainless steel collar</b>					
100	156629	(32 or 40) or 42	(32 or 40) or (42 or 50)	(32 or 40) or (42 or 50) or 54	0,36

All dimensions are in mm and nominal weights in kg

### PAM Konfix – For transitional connections

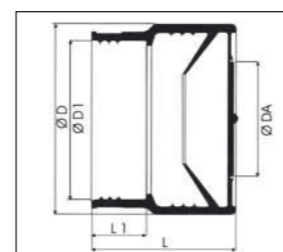

DN	Product code	D1	D	Ø Da Connecting pipe mm	L1	L	Insert depth mm	Weight
50	155759	57	72	40-56	20	58	35	0,11
70	155790	77	92	56-75	22	66.5	40	0,16
100	155833	108	126	102-110	27.5	89.5	57	0,30
125	155883	132	151	125	35.5	108.5	65	0,65

Transitional connectors DN 50- 125 are devoted to connecting cast iron ranges S and Plus to other materials, be they steel or plastic. The connections with these flexible connectors are easy and safe: one pre-cut lid and a lip seal

inside (see figure). EPDM and hose clamp made of chrome steel n° 1.4016

### PAM Konfix-Multi – For transitional connections

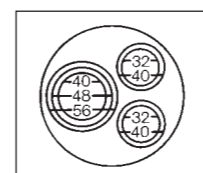

DN	Product code	D1	D	Ø Da Connecting pipe mm	L1	L	Insert depth mm	Weight
100	176811	108	134	32-56	35.5	90.5	40	0.30

To connect up to three pipes, 32-56 mm, made of other waste materials to a cast iron pipe system DN 100. EPDM and hose clamp made of chrome

steel n° 1.4016

### PAM Multiquick – For transitional connections

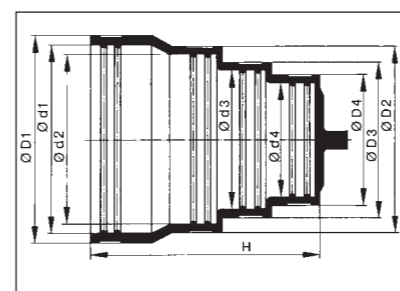

DN	Product	ØD1	ØD2	ØD3	ØD4	Ød1	Ød2	Ød3	Ød4	H	Weight
100 x 70	176812	117	111	101	81	108	104	94	74	107	0,15

The Multiquick connector DN 100x70 allows connections between other waste materials, with outside diameter ranking from 72 to 110 mm, to our cast iron range DN 100 with a maximum

outside diameter of 115 mm. Several pre-cut options. EPDM and hose clamp made of chrome steel n° 1.4016



## ABOVE GROUND APPLICATIONS

### Ductile iron brackets

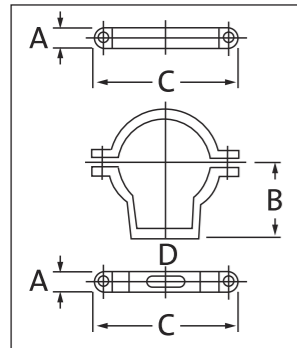

DN	Product code	A	B	C	Weight
<b>Ductile iron brackets</b>					
50	156408	27	64	110	0.30
70	156505	27	74	132	0.50
100	156646	27	90	166	0.60
150	156898	30	115	214	0.80
200	177745	35	150	266	1.60

Elongated slot at fixing point (D) to ease fixing

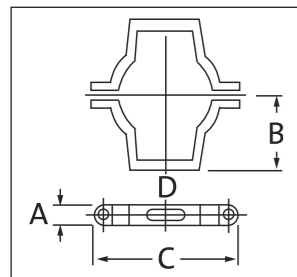

DN	Product code	A	B	C	Weight
<b>Ductile iron brackets</b>					
100	177744	27	90	166	0.80

Elongated slot at fixing point (D) to ease fixing

## BELOW GROUND APPLICATIONS

### Ductile iron brackets (Grey – ED048)



DN	Product code	A	B	C	Weight
100	175593	27	90	166	0.60
150	175594	30	115	214	0.80
200	177743	35	150	266	1.60

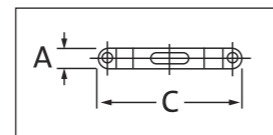
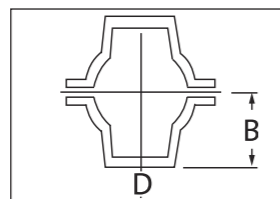
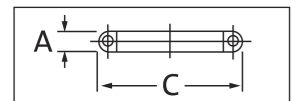

All dimensions are in mm and nominal weights in kg

## BRACKETING

### Cantilever Arm 36/40/2 - DN 50 to 150 - galvanised steel

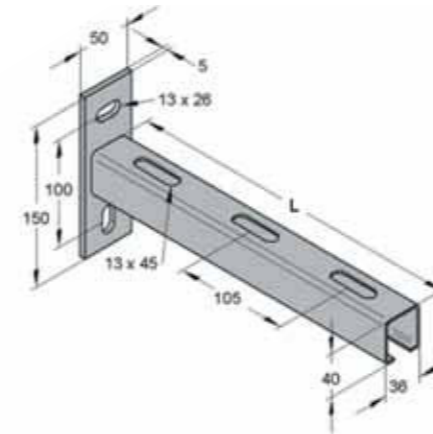

DN	Product Codes	L	F*	Weight
50	173646	210	260	0.60
75	173646	210	260	0.60
100	173647	315	260	0.85
125	173647	315	260	0.85
150	173647	315	260	0.85

(\*) F : maximum load for 2 arms, when applied at mid-length of the arm (L/2)

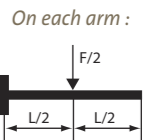

### Cantilever Arm 45/40/3 - DN 200 to 300 - galvanised steel

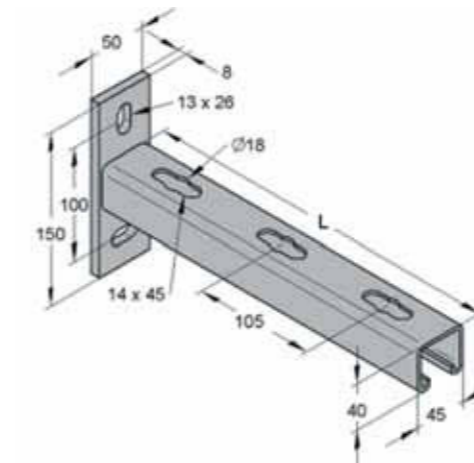

DN	Product Codes	L	F*	Weight
200	173648	315	680	1.40
215	173649	525	680	2.10
300	173649	525	680	2.10

(\*) F : maximum load for 2 arms, when applied at mid-length of the arm (L/2)

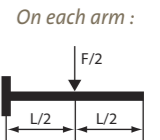

### Cantilever Arm 45/40/3 - galvanised steel

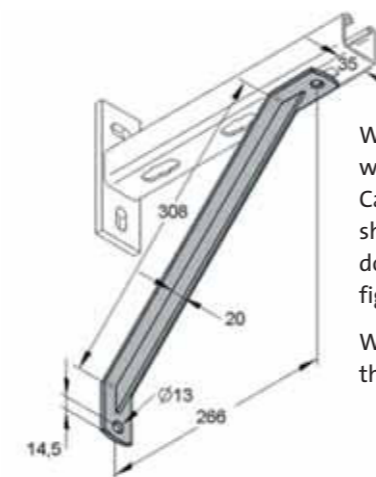

Warning : to be used only with the 525 mm length Cantilever Arm which should be fixed upside down as shown on the figure just below.

When bolt, the angle with the arm is 45°.

Product Codes	F*	Weight
173650	800	0.70

(\*) F : maximum load for 2 arms, when applied at mid-length of the arm (L/2)

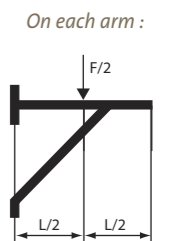

All dimensions are in mm and nominal weights and loads in kg



## SYPHONIC CAST IRON RAINWATER DRAINAGE SYSTEM

### EPAMS 100% metal outlets

#### Technical Approval 14+5/01-656 CSTB - for Roof Outlets and 14+5/01-656 \*01 Addendum

The EPAMS® system is a combination of SMU /ESIGN cast iron pipes, fittings and accessories, jointed with SMU Rapid 2® stainless steel couplings.

#### The EPAMS® outlets are made of 3 different parts:

- The Anti-Vortex mechanism, aluminium grating. Bolted on the bowl is the same for all the outlets.
- An identical stainless steel bowl for all the outlets, on which different components can be assembled depending on the field of use.
- A stainless steel tail available in four DN: 50 – 75 – 100 – 125.

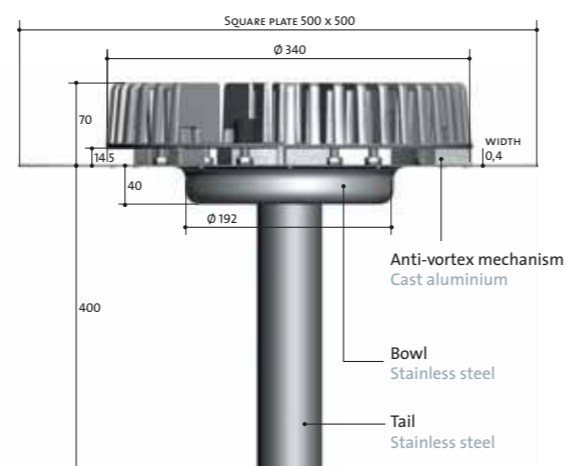

#### Installation

The EPAMS® outlets are easy to install. The installation has to be done in accordance to the good practice and the Technical Approval requirements.

SAINT GOBAIN PAM EPAMS all metal outlets full guarantee mechanical strength and durability.

They totally comply with EN 1253 on every specific point: flow capacity, watertightness, solidity, mechanical strength, heat resistance and climatic stresses (resistance to Ultra Violet...)

The grating and the anti-vortex mechanism are made in one piece. This allows quick removal with no risk of mistake at reassembling, easy intervention and maintenance.

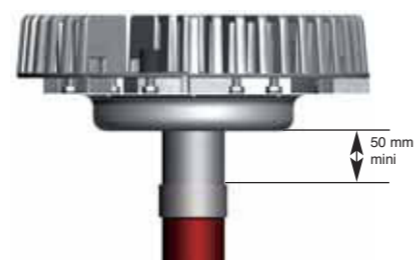

### EPAMS syphonic roof outlets range



#### EPAMS outlet to be welded

##### Application field:

This roof outlet is especially designed to be welded (or brazed) in gutters or in metal roof valleys

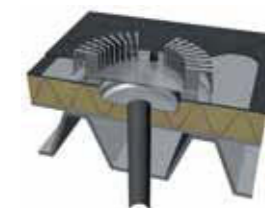

#### EPAMS outlet with flange

##### Application field:

This roof outlet can be used for roofs containing extra-thick metal gutters or valleys as well as for roofs waterproofed by synthetic or bituminous membranes

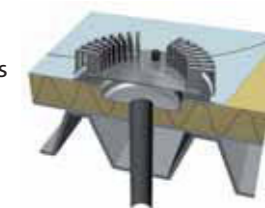

#### EPAMS outlet with steel plate

**Technical:** The plate is fixed to the roof outlet body in the factory by bonding then tightening with 6 nuts on the 6 bolts. This assembly can never be disassembled. The stainless steel plate is tinned on the two faces. Plate size 500 x 500mm with a thickness of 0.4mm.

##### Application field:

This roof outlet is used on all the roofs mentioned in the field of application of the French Technical Approval 14+5/01-656, except for those with waterproofing by synthetic membrane



#### EPAMS outlet for flexible PVC membrane

**Technical:** The plate is fixed to the roof inlet body in the factory by bonding then tightening with 6 nuts on the 6 bolts. This assembly can never be disassembled. The dimensions of the steel-PVC laminated plate are 500 x 500mm with a total thickness of 1.8mm. It consists of a galvanised steel sheet, thickness 0.62mm, covered in the factory on one face by a layer of epoxy (from SARNAFIL). The steel part contains 4-drilled holes for possible fixing to the roof. This plate is compatible with the PVC SARNAFIL membranes, Series G 410, of the "G 410" processes, to be applied as described by SARNAFIL.

##### Application field:

This roof outlet is used on non-accessible roofs and/or with equipment zones, and waterproofed by synthetic membranes according to the SARNAFIL Technical Assessment. Waterproofing is provided by a weld between the various PVC elements to seal it in a traditional way. The membrane may be visible or may be given heavy mineral protection. For this latter case, it is possible to use fine gravel but in this case the roof outlet is to be fitted with an elevating kit for the anti vortex mechanism (see next page)

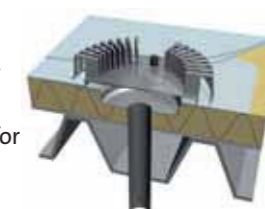

## SYPHONIC CAST IRON RAINWATER DRAINAGE SYSTEM

### EPAMS outlets to be welded



- Stainless steel body, including M10 bolts
- Aluminium grating

DN	Product code	DE mm	Weight kg	Capacity l/s	Surface Drainage m <sup>2</sup>
50	171283	58	5.4	13	260
75	171284	83	5.7	23	460
100	171285	110	6.4	26	520
125*	172850	135	8.3	26*	520

*This outlet is the basis for the three next outlets, on which are grafted various elements depending on the application field*

*See previous pages for main dimensions*

### EPAMS outlets with flange



- Stainless steel body, including M10 bolts
- Aluminium grating
- Aluminium flange

DN	Product code	DE mm	Weight kg	Capacity l/s	Surface Drainage m <sup>2</sup>
50	171288	58	6.2	13	260
75	171289	83	6.5	23	460
100	171290	110	7.2	26	520
125*	172871	135	9.1	26*	520

### Elevating kits for the anti vortex mechanism



90 mm



250 mm

Description	Dimension mm	Product code
Elevating device + anti vortex	90	171291
Elevating device + anti vortex	250	171292

*Anti-Vortex device fitted to Elevating Kit.*

*For roof with waterproofing protection by fine gravel or by flags on isolating layer by fine gravel.*

\* The advantage of the DN 125 outlet is in the "gutters" application where the water cover height can exceed the 55 mm figure (see French Technical Approval 14+5/01-656 - § 2.21)

### EPAMS outlets with steel plate



- Stainless steel body, including M10 bolts
- Aluminium grating
- Stainless steel plate - 500 x 500 mm

DN	Product code	DE mm	Weight kg	Capacity l/s	Surface Drainage m <sup>2</sup>
50	171081	58	6.4	13	260
75	171267	83	6.7	23	460
100	171305	110	7.4	26	520
125	172874	135	9.3	26*	520

*\* The advantage of the DN 125 outlet is in the « gutters » application*

### EPAMS outlets for flexible PVC membranes



- Stainless steel body, including M10 bolts
- Aluminium grating
- Laminate-steel PVC plate - 500 x 500 mm

DN	Product code	DE mm	Weight kg	Capacity l/s	Surface Drainage m <sup>2</sup>
50	171286	58	6.8	13	260
75	171287	83	7.1	23	460
100	171263	110	7.7	26	520
125	172876	135	9.6	26*	520

*\* The advantage of the DN 125 outlet is in the « gutters » application*

### Anchoring steel plate for EPAMS outlet with flange

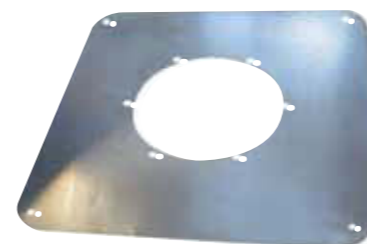

Description	Product code
Anchoring steel plate	172431

\* The advantage of the DN 125 outlet is in the "gutters" application where the water cover height can exceed the 55 mm figure (see French Technical Approval 14+5/01-656 - § 2.21)

# General conditions of sales

## Article 1 - GENERAL PROVISIONS

These general conditions of sale determine the rights and obligations of Saint-Gobain PAM ("SG PAM") and of the Client. All orders by the Client shall entail the Client's acceptance of these general conditions of sale. The Client's general conditions of purchase cannot prevail over these general conditions of sale unless SG PAM agrees thereto.

## Article 2 - ORDERS - ACCEPTANCE

- 2.1 Each order for products issued by the Client must be identified as being an order and must contain accurate and sufficient information concerning, for example, labelling and delivery, in order to allow SG PAM to process the order under the best possible conditions. If the information is insufficient or inaccurate, SG PAM may, without prejudice to any other solution, delay the product dispatch date.
- 2.2 Orders shall only become firm and definitive following the issue of an order acknowledgment by SG PAM. No order changes or cancellations can be taken into account after the order acknowledgment has been issued.

## Article 3 - PRICES

- 3.1 The prices invoiced shall be those prices that result from the price lists in force on the effective date of delivery or, if there is an offer, the prices contained in said offer, to the extent that the order reaches SG PAM during the period of validity of said offer.
- 3.2 When SG PAM issues an offer, the prices shall be firm for the duration of the offer or for a maximum of 3 months following the issue date of said offer. Thereafter, price increases may be applied.
- 3.3 Except as otherwise agreed, the prices are expressed in euros and net of all taxes. The prices shall be invoiced after application of value added tax at the rate in force.

## Article 4 - DELIVERY

- 4.1 The delivery times are minimum times and provided for information only. A delivery time is only firm if expressly described as such in the order acknowledgment.
- 4.2 Failure to comply with the indications concerning the delivery time does not authorise the Client to cancel its order, to defer payment for the order compared to the agreed conditions or to perform any form of withholding or offsetting whatsoever.
- 4.3 No default penalties may be claimed by from SG PAM unless the principle, terms and conditions of such penalties have been expressly accepted in the order acknowledgment.
- 4.4 SG PAM is not liable for failure to comply with delivery times when:
  - the Client did not comply with the payment conditions; or
  - when the information to be provided by the Client did not arrive in time;
- 4.5 The title to the products shall be transferred to the Client on SG PAM's premises as soon as the products can be identified individually and collected by the carrier.
- 4.6 The risks shall be transferred under the conditions defined by the chosen Incoterm (Incoterms published by the Paris International Chamber of Commerce in force on the effective date of delivery, the "Incoterms") or when the products are identified individually and collected by the carrier.
- 4.7 The terms "carriage paid" or "flat-rate carriage" correspond to the Incoterm CPT.

## Article 5 - INSPECTION

- 5.1 The products shall be inspected in the factory, in accordance with SG PAM's quality control procedures and the standards in force.
- 5.2 When it is agreed that a special inspection will be performed, by the Client or by an organisation that represents the Client, the inspectors who are responsible for performing the inspection shall be informed of the dates and times at which inspection operations must normally take place.

## Article 6 - TRANSPORT

- 6.1 When the Client organises the transport operations itself, the Client shall be responsible for fulfilling the obligations to adapt the vehicles to the products and the obligation to schedule loading 48 hours in advance. If not, loading will not be possible.
- 6.2 The Client shall be responsible for the unloading operations, which shall be performed under its supervision. In this respect, the Client must ensure compliance with the on-site safety conditions and make available suitable means in order to ensure the unloading takes place under the best possible safety conditions. In particular, in the event of delivery by crane truck, the Client shall assist the driver by unhooking the pipes and packages at ground level. The Client must draw up a safety protocol with the carrier prior to the unloading operations.
- 6.3 In the event of losses, damage or missing goods recorded at the time of delivery, the Client shall exercise its right of recourse against the carrier by mentioning reserves on the carrier's delivery note. The Client shall confirm said reserves and substantiate its claim to the carrier, by registered letter with return receipt, within 3 business days following the receipt of the products.

## Article 7 - PAYMENT TERMS

- 7.1 Payments shall be made to the address shown on the invoice, within 30 days end of month as from the invoice date of issue, regardless of the date of receipt of the products by the Client.
- 7.2 Accepted bills of exchange must be returned within 10 days of issue. This timeframe shall also apply to the orders to pay issued by the Client.
- 7.3 All payments made after the payment deadline shown on the invoice shall, by rights, trigger the invoicing of default penalties at a rate equal to three times the legal rate of interest in force.
- 7.4 If an invoice is not paid when due, all invoices that have fallen due shall immediately become payable. Moreover, SG PAM reserves the right to suspend the orders in process, without prejudice to damages.
- 7.5 No Client claims can lead to a change, delay or suspension of payments that have fallen due or authorise the Client to perform any offsetting or deduction whatsoever with the monies that are owed to SG PAM. All offsetting or deductions not agreed on beforehand shall constitute a payment incident that justifies the application of the measures referred to above.
- 7.6 In the event of a major change in the Client's legal or financial status, which has an impact on SG PAM's assessment of the Client's solvency or in the event of excessive amounts outstanding, SG PAM reserves the right, even after partially filling an order, either to demand guarantees or to cancel the remainder of the orders.

## Article 8 - PRODUCT WARRANTY

- 8.1 Without prejudice to the measures to be implemented vis-à-vis the carrier, claims regarding the non-conformity of the products delivered with the products shown on the order acknowledgment of receipt must be made in writing within 3 days of the receipt of the products. Thereafter, no claims shall be accepted.

- 8.2 SG PAM warrants the Client against the latent defects that may affect the sold products. If the Client notes a manufacturing defect in the product, which, in the Client's opinion, is characteristic of a latent defect, the Client must make a claim to SG PAM without delay.
- 8.3 Triggering the conformity warranty and the latent defects warranty is contingent on the existence of said defects being confirmed in the presence of both parties and acknowledged as being effectively attributable to SG PAM. The Client shall provide all proof of the reality of the conformity or latent defects observed. The Client must give SG PAM every opportunity to observe said conformity or latent defects and to correct them. The Client shall refrain from intervening on the products.
- 8.4 Within 1 month – all things remaining as is, except in the event of force majeure – the conformity or latent defect shall be recorded in an official document, in the presence of SG PAM's representatives.
- 8.5 If the existence of a conformity or latent defect is recorded in the presence of both parties and acknowledged by SG PAM as being effectively attributable to it, SG PAM shall take responsibility for repairing the product or supplying a product to replace the product previously delivered and shall pay the corresponding transport costs.
- 8.6 The Client is required, under its exclusive liability, to comply with the instructions given by SG PAM as well as with best practices for the handling and appropriate use of the products, as well as all the technical guidelines.
- 8.7 The guarantee provided shall not apply in the following cases:
  - apparent defect or a defect that a professional should have discovered;
  - defects and/or deteriorations caused by natural wear and tear or an external accident;
  - modification of the product that is not provided for or specified by SG PAM;
  - defects and/or deteriorations caused by a lack of compatibility with products not supplied by SG PAM;
  - failure by the Client to comply with the indications concerning the handling, the installation, the use and the maintenance of the products, as well as with best practices;
  - force majeure or an assimilated event.
- 8.8 The warranty granted by SG PAM shall last for 12 months as from delivery. Work carried out under the warranty shall not extend the warranty period.

## Article 9 - LIABILITY

Under no circumstances may SG PAM be held liable for the indirect material damages and for the direct and/or indirect consequential damages (such as operating loss or loss of clientele, compensation for delay, etc.), that are alleged by the Client, which may result from a failure to comply with SG PAM's obligations, in particular in the event of non-conformity or of a defect that affects its products.

## Article 10 - INDUSTRIAL PROPERTY

The plans, models, studies, results of tests, catalogues, manuals, and all the marketing and technical documents circulated by SG PAM, regardless of the media used, are the exclusive property of SG PAM. Consequently, the Client shall refrain from making any reproduction thereof whatsoever without SG PAM's prior agreement.

## Article 11 - MANUFACTURING - RECOMMENDATIONS

- 11.1 The weights and dimensions of the products stated on SG PAM's documents are theoretical values. SG PAM reserves the right to make all amendments to the information contained in its documentation.
- 11.2 The documents concerning the handling, storage, installation, use and maintenance of the products are supplied free of charge by SG PAM, at the Client's request. The Client alone shall be liable for compliance with the health and safety conditions for these various operations and for the use of the products in accordance with best practices.
- 11.3 SG PAM reserves the right to amend the data contained in these documents at any time. It is the Client's responsibility to verify the validity thereof with SG PAM.

## Article 12 - CONDITIONING

- 12.1 The product packaging is designed in order to meet haulage requirements.
- 12.2 The packaging and bracing wood not invoiced by SG PAM shall be recovered at the time of delivery.

## Article 13 - FORCE MAJEURE

- 13.1 SG PAM shall not be liable in the event of force majeure. Force majeure shall be understood to mean all causes that are beyond SG PAM's control, which would make it impossible to fulfil its contractual obligations and would affect the manufacturing, dispatch and delivery of the products. The following, inter alia, are deemed to be cases of force majeure: disturbances to production and/or delivery that result from war (declared or undeclared), strikes, lockouts, accidents, fires, floods, natural disasters, epidemics, interruptions or delays in haulage, shortages of materials and/or raw materials, embargos or regulations of any kind whatsoever.
- 13.2 In the event of force majeure, SG PAM shall have a reasonable supplemental timeframe in which to perform its obligations.

## Article 14 - APPLICABLE LAW - JURISDICTION

In the event of a contestation concerning the formation, performance or construction of the sale contract, solely the Nancy courts shall have jurisdiction, even in the event of multiple respondents, third party notices or emergency interim proceedings. French law shall be the applicable law.

## Logistic characterisation

**Obsolete pattern:** the pattern is no longer active. Should these components be ordered again, the quotation would include the re-activation of the tools.

**⚠ On a quotational basis:** these components are made to order. To secure delivery time, the related orders should be anticipated. Depending on the quantity ordered, a special logistic surcharge could also be applied.



# Section 3

## Specifier's Manual

### SAINT-GOBAIN CAST IRON PIPE SYSTEMS 1ST CHOICE FOR PROJECT MANAGERS AND PROFESSIONAL INSTALLERS

- Project support - assistance from our Technical Departments and commitment of our sales teams, to advise and help you to make the right choice.
- Traditional and precise mechanical assembly – with simple tools, without gluing or welding, to overcome on site difficulties.
- Simple to install, cast iron systems do not require specially trained installers to complete the installations.
- Dependable installation– SMU-Ensign ranges minimise the risk of error and help reach the expected performances immediately.

# Design recommendations



## Installation features

### Preparation

Cast iron pipe systems for drainage mainly consist of spigot pipes - generally supplied in 3 m length - and fittings of various shapes (bends, branches, etc.). The cast iron pipes can be cut to length. Where pipes are cut on site, ends shall be cut clean and square with burrs removed and then re-coated with the adequate touch-up paints EXTREM 1 mentioned on pages 33 and 55, or other repair products recommended by SAINT-GOBAIN PAM.

### Cutting techniques

SMU pipes can be cut easily and quickly using either of the following methods. It should be ensured that cutting procedures comply with the safety guidelines from the cutting tool manufacturer's operating manual.

**WARNING** Chain or compression type cutters should not be used.

	Hacksaw	Pipe cutter	Band saw	Powered disc cutter
<b>S And Plus ranges</b>				
DN40				
DN50				
DN75				
DN100				
DN125				
DN150				
DN200				
DN250				
DN300				
DN400				
DN500				
DN600				
<b>FLUTED RAINWATER RANGE</b>				
DN75				
DN100				

Reciprocating saw can be used, but is not fully adapted.

## Quick and reliable installation: long tail branches.

In new construction projects, long tail branches installed through the slabs, offer reliable and ergonomic solutions to connect sanitary appliances.

The long tail branches fully meet the standard EN 12056, with several shapes and different products for grey water and black water available: Single branches, double or corner branches. These products exist in push-fit or spigot versions. They can be fitted with elastomer plugs to easily perform several connections.

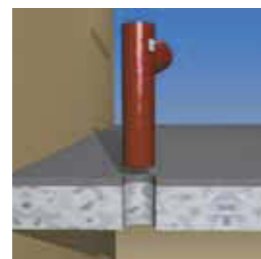

Adjustable height for use whatever the slab depth



A 360° rotation, to easily position the branch according to the layout of the appliances



The jointing is easily made under the slab and abates the access problem for push fitting or installation of the coupling within the slab.

## Modifications to an existing installation.

### Typical example spigot system

1. Measure length of branch, adding a further 15mm in total to allow for coupling's central register top and bottom.
2. Make sure existing pipework is adequately supported from above.
3. Mark pipe position for cutting.
4. Cut pipe using powered disc cutter or wheel cutter and remove sharp edges.
5. Coat cut ends with appropriate touch-up (epoxy coating).
6. Push the rubber gaskets onto the spigot cut ends top and bottom, ensuring the central registers are abutted against each spigot edge.
7. Position fitting in the stack within each rubber gasket abutting against the central registers.
8. Loosely assemble the coupling around each gasket.
9. Check alignment of assembly before tightening the bolts, to recommended level, depending on the couplings technical recommendations.
10. Test new stack for successful joints.



X = fitting + 15mm

### Typical example push-fit system

The same can be made with the SME push fit system using slip fittings.

The slip fittings allow modifications on existing stacks and make the replacement of pipework sections easier.

The slip branch allows the installation, on an existing stack, of a perfectly operational branch connection.

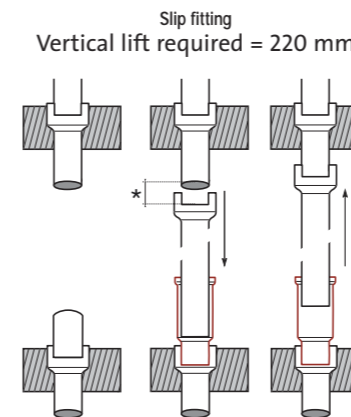

Slip fitting  
Vertical lift required = 220 mm

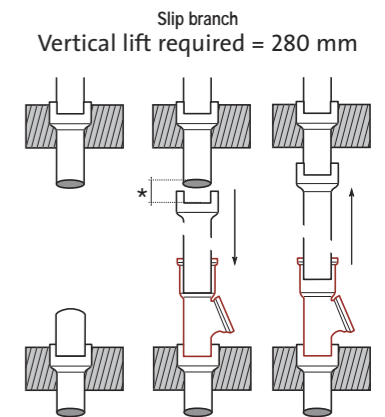
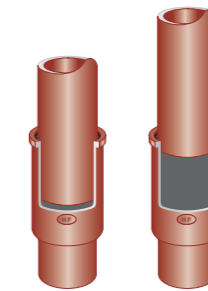

Slip branch  
Vertical lift required = 280 mm

### Replacement of a branch included into a slab by a long tail branch.

During a building renovation, the replacement of branches embedded in concrete can be very delicate and generate costly repairs.

See below for a safe, non destructive and simple procedure:

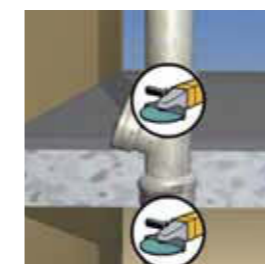

Cut the existing branch just above the slab



Break the former pipe parts included in the slab

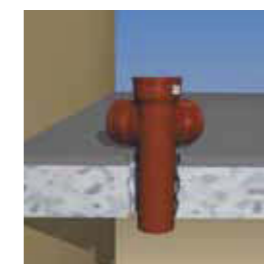

Insert the new branch long tail into the slab



Proceed push fitting the other elements



Seal the openings with cement or sealant.

# Design recommendations

## Joining methods

### Stainless steel couplings

Some models can be assembled in two parts and other can be assembled as a sleeve.

#### Separate Assembly

##### PAM CV- CE couplings and PAM SMU Rapid 2 Couplings

The couplings consists of two parts: a stainless steel strap and an EPDM sealing gasket

Tools: screwdriver, ratchet or electric screwdriver.

The tightening torques need to be respected, standard manual tightening torques are:  
 PAM CV coupling: 8-10 N.m for all DN  
 PAM CE coupling: 5-8 N.m for DN50-75/80  
 10-12 N.m for DN 100-125  
 12-15 N.m for DN 150-200  
 SMU Rapid®2: 4 N.m for all DN



Push the supplied sealing gasket on to the pipe spigot so it abuts the gasket central register

Roll back the open half of the sealing gasket

Install the next spigot and unfold the gasket half back.

Place the steel strap around the sealing gasket

For PAM CV-CE couplings: Alternately tighten the two tightening screws uniformly and hand tight. The threaded plates must come together parallel to avoid any deformation.

For SMU Rapid 2: same procedure and then, tighten the single hexagon head screw

#### Assembly as a sleeve

##### PAM Rapid NG couplings

Couplings are supplied pre-assembled.



Push the supplied assembled coupling onto the pipe spigot so that it abuts on the central register of the elastomer gasket.

Push the next pipe spigot into the other end of the coupling.

Tighten the screw to "nul gap" position, that is fully closed, with a ratchet spanner or an electric screwdriver.



The PAM Rapid NG is designed to be tightened to fully closed there is no need for checking the torque.

### PAM Rapid 250-300 coupling - Special design:

can be assembled two different ways, depending on if an open strap is required.



#### Standard assembly:

- 1 Open the stainless steel strap.
- 2 Slide the stainless steel strap loose, around the first pipe component.
- 3 Push the sealing gasket onto the component spigot so it abuts on the central register of the gasket.
- 4 Push the second component into the sealing gasket, so that it abuts on the central register.
- 5 Bring the steel strap over the sealing gasket.
- 6 Tighten the bolt with a ratchet spanner or a power tool applying the following tightening torque: DN 250 and DN 300=25 N.m.



#### Open strap assembly:

An open strap is sometimes required to ease access: stack installation etc...

- 1 Push the rubber gaskets onto the spigot ends top and bottom, ensuring the central registers are abutted against each spigot edge.
- 2 Twist the stainless steel strap to ease the wrapping around the pipe components.
- 3 Clip the bolt and loosely assemble the coupling around the gasket.
- 4 Check alignment of assembly before tightening the bolt with a ratchet spanner or a power tool applying the following tightening torque: DN 250 and DN 300= 25 N.m.

FAQ

### Electrical continuity and stainless steel couplings.

Stray currents liable to cause corrosion may originate from direct-current distribution lines, substations, or street railway systems, and flow into a pipe system or other steel structure. The corrosion resulting from stray currents is very similar to that from galvanic cells. The one resulting from direct-current being the most severe.

To avoid electrocution hazard to the plumber or occupants and premature corrosion of the pipe systems where stray currents are to be feared, different remedial measures may be indicated to ensure electrical continuity (equipotential bonding):

- PAM Rapid NG couplings: the profile of the steel strap - with edges directed towards the pipe - ensures when fully tightened, a built-in electrical continuity, without any added clip.
- PAM CV-CE NG and SMU Rapid2 couplings : the profile of their straps is flat. To ensure electrical continuity one clip should be added between the rubber gasket and the steel strap (available on request). To ensure metal-metal contact the paint on the pipe shall be removed where the clip will rest.

Added clips	Product code	DN	Weight (g)
	156395	50-75	6
	156631	100-125-150	8
	156996	200-250-300	10

For ductile iron couplings refer to p 94

# Technical characteristics

## Couplings technical features

	PAM CV NG	All stainless steel PAM CE NG	PAM Rapid NG W2	All stainless steel PAM Rapid NG W5	SMU Rapid 2	All stainless steel SMU Rapid 2	Rapid S NG 250-300	All stainless steel Rapid NG 250-300	PAM-FLEX S INOX	PAM-GRIP S INOX
<b>Strap/case material (1)</b>	Stainless Steel 1.4510/11 (430Ti/439)	Stainless Steel 1.4301 (304)	Stainless steel 1.4510 /11 (430Ti / 439)	Stainless steel 1.4404 / 1.4571 (316L/316T)	stainless steel DN 40: 1.4510 (430 Ti) DN 50 200: 1.4310 (301)	stainless steel DN 40: 1.4571 (316 Ti) DN 50 200: 1.4310 (301)	Stainless steel 1.4510 /11 (430Ti / 439)	Stainless steel 1.4404 / 1.4571 (316L/316Ti)	S: Austenitic stainless steel 1.4307 (304L) Inox: Austenitic stainless steel 1.4404 (316L)	S: Austenitic stainless steel 1.4307 (304L) Inox: Austenitic stainless steel 1.4404 (316L)
<b>Screws</b>	Hexagonal head screw		Allen							
<b>Wrench dimension (in mm)</b>	All diameters 10		DN 50 150: 6 DN 200: 8		DN 50 150: 6 DN 200: 8		DN 250 DN 300: 8		FLEX: DN 100 150: 6 DN 200 600: 8	GRIP DN 100: 6 DN125 150: 8 DN200 600: 10
<b>Number</b>	2	2	1	1	1	1	1		FLEX: DN 100 300: 2 DN 400 600: 3	GRIP DN 100 150: 2 DN200 600: 3
<b>Screws Material</b>	Coated Steel class 8.8 (minimum of 350 h/salt spray test)	Coated stainless Steel A2 70	Coated steel class 8.8	Coated stainless steel A4 70 1,4404/1,4571	Steel, grade 8.8 ZnAl plated	Stainless steel Class A4 (2)	Coated stainless steel A2 70	Coated stainless steel A4 70	S: 1.4301 (304) Inox: 1.4401 (316)	S: 1.4301 (304) Inox: 1.4401 (316)
<b>Tightening torque (in N.m)</b>	8 10 N.m for all DN	5 8 N.m for DN50 75/80 10 12 N.m for DN 100 125 12 15 N.m for DN 150 200	Nul gap tightening No use checking torque		DN 50 200: 4		DN 250 300 : 20 30 N.m	DN 250 300 : 20 30 N.m	See details pp 69 70	See details pp 69 70
<b>Clamp and barrel</b>	Plates		Clamps		Clamps		Clamps		Barrels	
<b>Material (1)</b>	Stainless Steel 1.4373 or 1.4510/11 or AISI 202 or AISI 430Ti/43	Stainless Steel A2 70 or 1.4301 or AISI 304	Stainless steel 1.4301 or 1.4510 /11 (304or 430Ti / 439)	Stainless steel 1.4404 / 1.4571 (316L/316T)	Stainless steel 1.4510 (430Ti)	Stainless steel 1.4301/1,4571 (304/316 Ti)	Stainless steel 1.4301 or 1.4510 /11 (304or 430Ti / 439)	Stainless steel 1.4404 / 1.4571 (316L/316Ti)	S: Austenitic stainless steel 1.4307 (304L) Inox: Austenitic stainless steel 1.4404 (316L)	S: Austenitic stainless steel 1.4307 (304L) Inox: Austenitic stainless steel 1.4404 (316L)
<b>Number</b>	2	2	2	2	2	2	2		2	2
<b>Sleeve (gasket)</b>	EPDM	EPDM	EPDM	EPDM or Nitrile	EPDM	EPDM	EPDM		EPDM or NBR	EPDM or NBR
<b>Performances</b>	In compliance with EN 681 1 December 1996 Type WC									
<b>Maximum deflection (4)</b>	DN 50 200: 3° DN 250 600: 1,45° (5)								DN < 200: 3 DN > 200: 1,5°	
<b>Maximum misalignment (4)</b>	Corresponding to a shearing load of 10 X DN in Newton, limited to 6mm, under an internal pressure of 1 bar									
<b>Hydrostatic test pressure</b>										See details pp 69 70

- (1) First grade is according to EN 10027-2, grade in brackets to the closest AISI one considering equivalences between standards  
 (2) As per EN ISO 3506-1  
 (3) Standard tightening to reach EN 877 requirements. For higher requirements on pressure resistance, "nul gap" tightening should be applied.  
 (4) See EN 877 for more details  
 (5) Where couplings are used with grip collars, or for SMU-S Autogrip couplings, deflection should be applied before tightening the bolts/screws

Note: 1 bar = 100 kPa = 0.1 MPa ≈ 1 daN/cm² ≈ 10 m water column

## Couplings + grip collars: performance level

Couplings	Grip collars	DN	Address end thrust effort for a pressure of (in bars)					
			3b	5b	10b	10b	10b	10b
 PAM CV/CE	 PAM Grip Collars	50 - 125						10b
		150 - 200			5b			
		250 - 300		3b				
 PAM RAPID NG		50 - 125						10b
		150 - 200			5b			
		250 - 300		3b				
 SMU RAPID 2	50 - 125						10b	
	150 - 200			5b				
	250 - 300		3b					
 HP GRIP - S	100 - 300						10b	
	400							
	500		3b					
	600		2b					
 HP GRIP - NOX	100 - 400						10b	
500				6b				
 Expansion plug	 PAM Grip Collars for Expansion plugs	600			4b			
		50 - 125						10b
		150 - 200			5b			

# Design recommendations

## Joining methods

### Ductile iron couplings

Couplings are supplied pre-assembled. In certain applications, it can be beneficial to apply a small amount of lubricant ( i.e PAM lubricant see page 95) on the lip of the rubber gasket to ease its positioning.



Slacken bolts on coupling to fullest extent, removing the bolt(s) from one side to ease assembly and remove rubber gasket.



Place the rubber gasket over the end of the pipe or fitting, ensuring the central register is abutted against the spigot edge.



Push the second pipe or fitting into the gasket again ensuring that the spigot is abutted against the central register.



Loosely assemble the coupling around the gasket.



Check alignment of assembly before tightening the bolts. Coupling bolts on all sizes are M8 and require special allen socket adaptor.

Two-piece ductile iron couplings

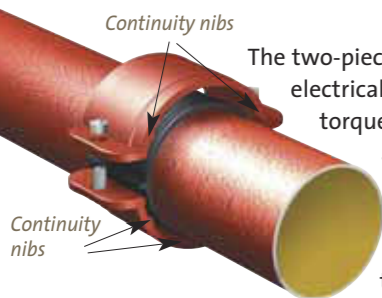

### Electrical continuity for ductile iron couplings

The two-piece ductile iron couplings are supplied with four iron nibs to each half-piece, providing electrical continuity (equipotential bonding) automatically when tightened to the recommended torque. The installation should be tested in accordance with EN 12056-2 for gravity drainage, and EN 12056-3 for rainwater, and with the local wiring regulations on equipotential bonding (earthing). Provided that the electrical continuity coupling is assembled and installed as recommended in our instructions (see above) and the pipework is bonded to the electrical earth or similar earth, the electrical continuity coupling should satisfy the UK IEE wiring regulations\*. It is recommended that the installation is regularly checked for equipotential bonding (earthing) in case of accidental damage, unauthorised pipework, modifications etc. If an electrical continuity installation is to be modified for any reason, electrical continuity couplings must be used and the installation re-tested for equipotential bonding (earthing).

If provision is made for electrical continuity, the electrical resistance of the coupling shall not exceed 0.3 ohms. Apply a steadily increasing voltage not exceeding 50V ac, 50 Hz, across the junction until a steady current of  $25 \pm 1A$  flows through the coupling. Allow the current to flow for 30 s, maintaining it as necessary by adjusting the voltage. Calculate the resistance of the coupling by dividing the observed voltage by the current.

\* Check it does not contravene the local wiring regulations.

### Push-fit systems

#### SME Range

#### Socket pipes and fittings



Insert the gasket into the socket



Apply a small amount of jointing lubricant on the pipe or fitting spigot, rather than on the rubber gasket to ease the fixing.



Push joint into the pipe or fitting socket, ensuring the central register is abutted against the spigot edge evenly.



Remove any excess lubricant.

#### EEZI-FIT Range

#### Plain spigot pipes and socket fittings.



Apply a small amount of jointing lubricant on the lip of the rubber gaskets, both ends to ease insertion of pipe/fittings.



Push joint over the end of pipe, ensuring the central register is abutted against the spigot edge evenly.



Push the second pipe or fitting into the gasket again ensuring that the spigot is abutted against the central register.

When jointing to pipe which has been cut, please remove any sharp edges (chamfering is not necessary).

Saint-Gobain PAM recommends the use of its own jointing lubricant available in 0.5 kg tubs and proven to be perfectly adapted not to damage the EPDM.

Product Code of the lubricant: 199037.

(Please read health and safety instructions when using this product).





# Design recommendations

## Connection to other materials

### Branch connections to waste pipes in small diameters

The easiest way to connect cast iron systems to other drainage materials is to use rubber connectors or plugs. Flexible couplings and stepping rings are also available to ease connections where variances in diameters have to be compensated.



Konfix

Konfix-Multi

Rubber transitional connectors PAM KONFIX and PAM KONFIX-Multi are used to connect waste pipes made of other material (steel or plastics) to a PAM cast iron pipe system.



1. Insert the PAM KONFIX rubber connector loosely onto the pipe until the stop point is reached. Then secure to the pipe by tightening the hose clamp screw.

2. Cut the pre-cut rubber to size with a knife and remove the lid. **WARNING:** Do not cut too deep as may damage the lip seal inside!

3. Mark the insert depth on the connecting pipe. Apply a lubricant and push in. The assembly is completed.

4. The connecting steel pipe illustrated here is only an example. The PAM KONFIX rubber connectors can be used to connect all waste pipe materials to the PAM cast iron systems.

### EPDM plugs

The plugs can be pierced to the appropriate groove from 32mm up to 54mm waste connections and tear out centre disc where required.

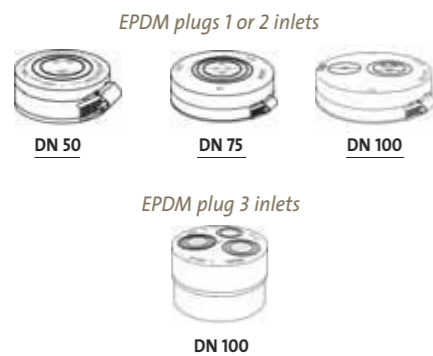

### PAM MULTIQUICK, transitional connector.



To connect PAM cast iron pipes with an outside diameter of 109-112 mm (tolerance range for PAM cast iron pipes DN 100) to other rigid materials with an outside diameter range 110-72 mm.

To connect PAM cast iron pipes with an outside diameter of 109-112 mm to waste pipes with an outside diameter up to 115 mm maximum. The connection is made with two hose clamps both suitable to address larger diameter tolerances.



1. Push the open end of the PAM MULTIQUICK connector over the pipe end and place the hose clamp to its tightening position.

2. Then use a knife to cut open the pre cut lid to the corresponding outside diameter of the connecting waste pipe. Then push the second hose clamp loose over the connecting rubber end.

3. Push the connecting pipe into the PAM MULTIQUICK connector and tighten the hose clamp in the right position. Ensure that the sealing zones (face ends of pipes or fittings) are clean: remove paint flakes and cement residues. The hose clamps should only be tightened manually with a screwdriver in order to avoid any damage to the PAM MULTIQUICK rubber connector.

### Boss pipe compression fit

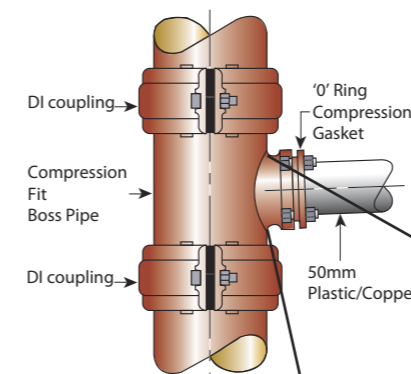

The boss pipes incorporate 'O' ring compression gaskets that will accept 54-56mm O/D pipe, and is supplied assembled with the following for each boss.

1. 6mm 'O' ring rubber (EPDM)
2. M8 x 30 zinc and clear coated steel screw x 2
3. M8 coated steel nuts x 2

To connect 32mm and 38mm waste pipes fit the appropriate reducing adaptors onto the pipe before inserting through the clamp flange. The 'compression fit' boss pipes have been introduced to reduce the cost of connecting to waste pipes, eliminating the need for expensive conventional threaded male adaptors, and subsequently reducing the overall installation costs.

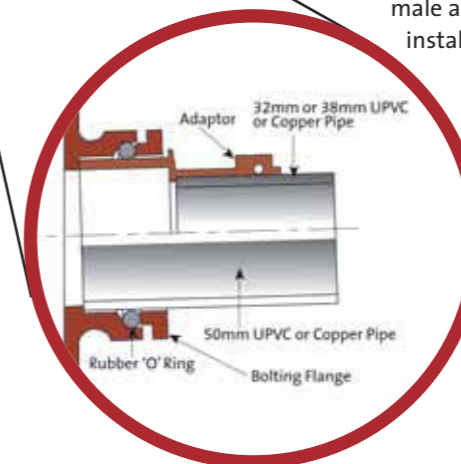

# Design recommendations

## Connection to other materials

Connecting cast iron pipe systems to other materials may be required in new construction projects or to ease refurbishment. Their external diameters may differ and solutions exist for compensation.

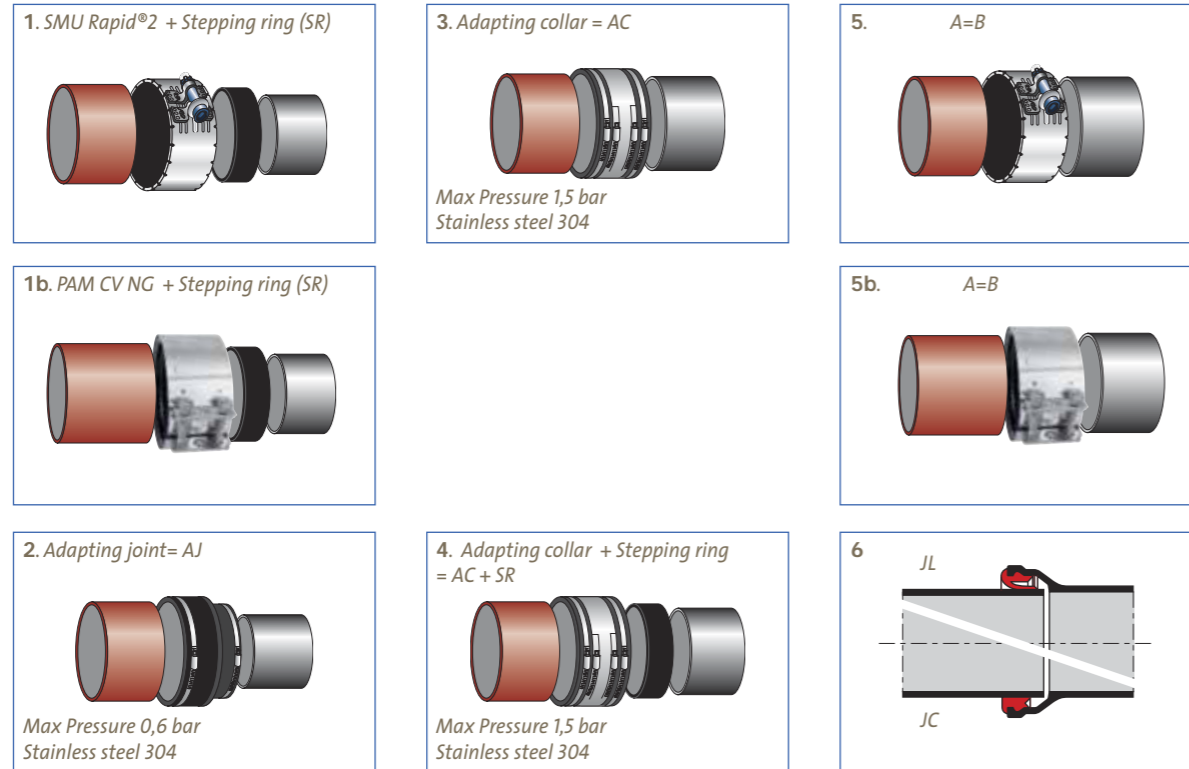

The PAM Rapid NG couplings can be used instead of SMU Rapid® 2 or PAM CV-CE couplings, but for aesthetical reasons, they are not recommended for type 1 installations.

DN	Material of existing network	DE in mm	Circumference in mm	Type of joint	Product code	Admissible tolerance couplings (mm)		Figure		
						DE	Circumference			
50	P.V.C	50	157	SMU Rapid®2 + SR	157635	55 60	172 188	1		
				PAM CV NG + SR	156399	49 52	153 163	1b		
					210398	55 60	172 188			
	HDPE	50	157	SMU Rapid®2 + SR	157635	55 60	172 188	1		
				PAM CV NG + SR	156399	49 52	153 163	1b		
					210398	55 60	172 188			
75	P.V.C	75	235	SMU Rapid®2 + SR	157638	81 86	254 270	1		
				PAM CV NG + SR	156494	75 79	235 248	1b		
					210413	81 86	254 270			
		SME "JL"	156076	58 79	182 248	6				
			HDPE	63	197	SMU Rapid®2 + SR	157638	81 86	254 270	1
						PAM CV NG + SR	156494	75 79	235 248	1b
	210413	81 86					254 270			
	SME "JL"	156076	58 79	182 248	6					
		75	235	SMU Rapid®2 + SR	157638	81 86	254 270	1		
				PAM CV NG + SR	156494	75 79	235 248	1b		
	210413				81 86	254 270				
	SME "JL"	156076	58 79	182 248	6					

DN	Material of existing network	DE in mm	Circumference in mm	Type of joint	Product code	Admissible tolerance couplings (mm)		Figure				
						DE	Circumference					
100	PVC	100	314	SMU Rapid®2 + SR	157641	107 112	335 351	1				
				PAM CV NG + SR	156635	99 102	310 320	1b				
					210416	107 112	335 351					
		SME "JL"	156132	78 106	244 332	6						
			HDPE	110	345	SMU Rapid®2	157641	107 112	335 351	5 or 5b		
						or PAM CV NG	210416	107 112	335 351	6		
	or SME "JC"	156133					78 106	244 332				
	Steel	114	358	SMU "AC"	155002	100 115	314 361	3				
					Clay	132	414	SMU "AJ"	Consult us	110 115	345 361	2
								130 145	408 455			
	125	PVC and HDPE	125	392	SMU Rapid®2 + SR	157645	133 138	417 433	1			
					PAM CV NG + SR	156778	123 127	386 398	1b			
210417						133 138	417 433					
Steel		139	436	SMU "AC"	TXB12NLOG	130 150	408 471	3				
					Clay	159	499	SMU "AJ"	Consult us	121 136	379 427	2
								144 160	452 502			
150	P.V.C	140	439	SMU "AJ"	155003	130 145	408 455	2				
				155 170	486 534							
	PVC and HDPE	160	502	SMU Rapid®2	157648	158 164	496 514	5				
				PAM CV NG	210418	158 164	496 514	5b				
	Steel	168	527	SMU "AC"	TXB15NMOJ	150 175	471 549	3				
					Clay	186	584	SMU "AJ"	Consult us	144 160	452 502	2
170 193	533 606											
200	PVC and HDPE	200	628	SMU Rapid®2 + SR	157650	207 213	649 668	1				
				PAM CV NG + SR	157000	198 202	621 634	1b				
					210420	207 213	649 668					
	Steel	219	688	SMU "AC"	TXB20NLOK	200 225	628 706	3				
					Clay	242	760	SMU "AJ"	Consult us	204 219	640 687	2
								238 254	747 797			
250	PVC and HDPE	250	785	SMU Rapid®2 + SR	183904	271 276	850 868	1				
				PAM CV NG + SR	157085	248 252	778 791	1b				
					210422	271 276	850 868					
	Steel	273	857	SMU Rapid®2	183904	271 276	850 868	5				
					Clay	296	929	SMU "AC" + SR	TXB25NQOL	285 310	894 973	4
								270 290	847 910			
300	PVC and HDPE	315	989	SMU "AC"	TXB30NN02	310 335	973 1051	3				
				Steel	324	1017	SMU Rapid®2	183905	323 328	1014 1031	5	
	Clay	350	1099				PAM CV NG	210423	323 328	1014 1031	5b	
				SMU "AC" + SR	TXB30NQOM	320 340	1005 1068	4				
	335 360	1051 1130										

### Specific DN 70 / 75 connection with SMU Rapid 2



Product code : 156494 157638  
1. Stepping ring SMU Rapid®2

2. Fit the rubber gasket to DN 70 pipe end first

3. Fit the SMU Rapid®2 rubber gasket to both pipe ends

4. Apply SMU Rapid®2 tightening strap, pull tightly and screw.

# Design recommendations

## Requirements and permissible pressure load

### Standard requirements according to EN 12056

Gravity waste water drainage systems and ventilation systems generally operate without pressure. This does not exclude however, the possibility of pressure arising in the systems under specific operating conditions.

EN 12056-1, Section 5.4.2 Water and Gas Tightness, states that drainage installations must be sufficiently water and gas tight to withstand pressures arising in operation.

Furthermore, EN 12056-5, Section 6.3 states relating to securing pipe systems: Non anchored pipes must be secured and/or supported in such a manner that they cannot be disconnected during use. The arising reaction forces must be addressed.

### Definitions

Fluid pressure is the force the fluid exerts by surface unit, perpendicularly to this surface.

**Pressure change applied** to the surface of an enclosed **fluid** is transmitted evenly and undiminished in all directions. Robust cast iron components can address any pressure hazard, so the couplings will be submitted to the strain.

Couplings designed by SAINT-GOBAIN PAM are tested in hydrostatic pressure; grip collars and autogrip collars only are tested under end thrust forces.

### FAQ

#### Pressure definitions

**Hydrostatic pressure:** outward pressure exerted by a non-moving (static) fluid everywhere perpendicular to the pipe walls or any other pipework element, like joints.

When it is stated that a coupling withstands a 5 bar hydrostatic pressure it comes to considering the coupling water tightness under this pressure only, whilst considering that the two spigots are affixed so that dislocation forces are addressed.

**End thrust effect:** resultant forces from the pressure exerted by a static fluid on specific pipework elements (or direction changes) i.e:

- Straight run (pipes): the stresses cancel



- Specific (for i.e fitting): the resultant force tends to disconnection

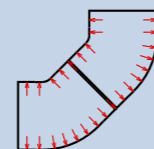

### PAM grip collars installation



Position the two half parts of the PAM grip collar uniformly so it encircles the pipe in parallel. The grip collars must be positioned so that the apertures fit over the fixing bolts of the coupling and the teeth are directly located onto the pipe.



Insert the four screws to fix the two parts together loosely.



Tighten the screws crosswise alternately so that the two plates are put in parallel with the same spacing.



The assembly is completed when the external edges of the plates are in contact on both sides.

### Requirements and permissible pressure loads for couplings

Conditions when drainage pipeworks may be exposed to an internal pressure higher than 0.5 bar:

1. Pipes laid under the groundwater table
2. Rainwater pipes or wastewater pipes running through several storeys without outlets
3. Pipework operating under pressure for wastewater pumped installations

### Straight runs of the pipework

Straight runs between two fixed points do not experience exceptional forces, grip collars are then not necessary. In case of accidental overloading, the couplings will only have to address hydrostatic pressure. They generally withstand: 5 bar for couplings like PAM Rapid 5 or PAM SMU Rapid 2 from DN 40 to 200 3 bar for the same couplings for DN 250 and 300

### Changes of direction and specific elements

End thrust forces can exert in changes of direction, gradient and specific components like branches and plugs for example. In these areas, the forces have to be addressed to avoid any risk of disconnection or slippage of the pipe system:

- isolating the section subjected to thrust forces between two fixed points, like stack support pipes i.e and
- adapting the joints (selection of couplings + installation of grip collars) between these fixed points.

To address the thrust forces, other solutions can be resorted to, like anchoring in concrete, use of thrust blocks...

Remark: under end thrust forces, where a coupling is secured with a grip collar, the maximum performance of both is limited by the weakest performance of the two products.

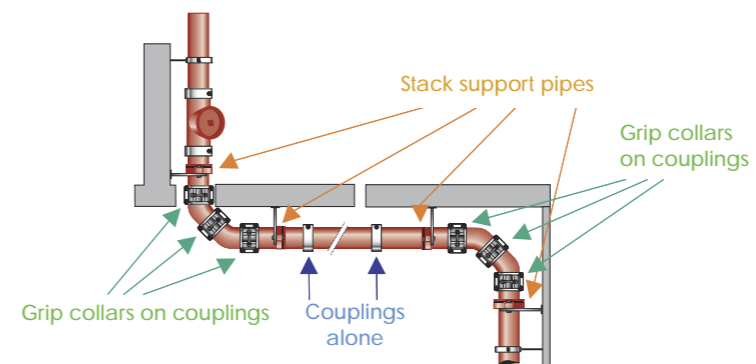

### End thrust force under a 1m water column (kg.F)

	DN 50	DN 75	DN 100	DN 125	DN 150	DN 200	DN 250	DN 300	DN 400	DN 500	DN 600
Expansion plug	2,1	4,6	8,5	13	18,5	32,2	55,4	78,7	135,5	209,8	301,4
2 45° bends	3	6,5	12	19,4	26,1	45,5	78,3	111,2	191,6	296,6	426,2
Stack bottom	2,1	4,6	8,5	13	18,5	32,2	55,4	78,7	135,5	209,8	301,4

Ensure that the installation instructions for couplings and grip collars are observed.

See coupling performances on page 93

### Specific applications: Rainwater pipes

EN 12056-3, Section 7.6.4., stipulates: Internal rainwater pipes shall be able to withstand the head of water likely to occur in the event of a blockage.

The same precautions as on a pipework liable to undergo accidental overloading should be taken: securing of bottom bends and joints with the adequate grip collars.

# Design recommendations

## Ventilation

A drainage pipe is normally at neutral air pressure compared to the surrounding atmosphere. When a column of waste water flows through a pipe, it compresses air in the pipe, creating a positive pressure that must be released or will push back on the waste stream and downstream traps' water seals. As the column of water passes, air must flow in behind the waste stream or negative pressure (suction) results. The extent of these pressure fluctuations is determined by the fluid volume of the waste discharge.

The purpose of ventilation stack is to control pressure in the pipework in order to prevent foul air from the waste water system entering the building. You will find below some major configurations principles, but combinations and variations are often required. **See standard EN 12056-2**

Black water and grey water can be drained either in separate or in a single discharge stack. According to the selected option, the rules for duct sizing are different.

### Primary ventilated system configurations:

Control of pressure is achieved by air flow in the discharge stacks. The soil stacks extend in main roof vents to above and out of the roof. Alternatively, air admittance valves may be used. They are pressure-activated, one-way mechanical vents, used in a plumbing system to eliminate the need for conventional pipe venting and roof penetrations.

### Secondary ventilated system configurations

**In buildings of three or more storeys** - if the air pressure within the stack becomes suddenly higher than ambient, this positive transient could cause waste water to be pushed into the fixture, breaking the trap seal.

Vent stacks are put in parallel to waste stacks to allow proper venting and prevent such disorders. Air admittance valves may also be used, in this configuration.

Under many building codes, a vent stack, a pipe leading to the main roof vent, is required to the draining fixtures (sink, toilet, shower stall, etc.).

*A single stack is still possible but design precautions have to be taken to prevent self-siphonage.*

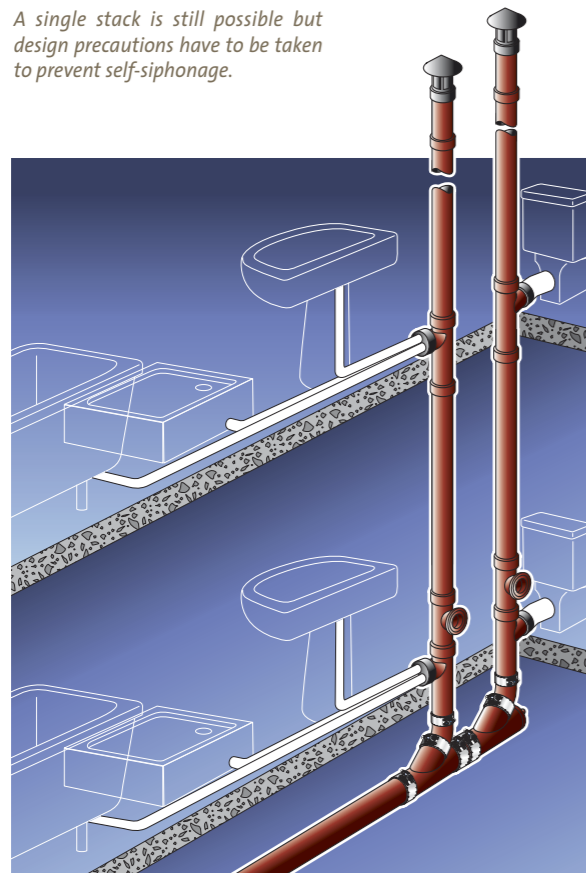

*To allow only one vent stack, and thus one roof penetration as permitted by local building code, sub-vents may be tied together and exit a common vent stack.*

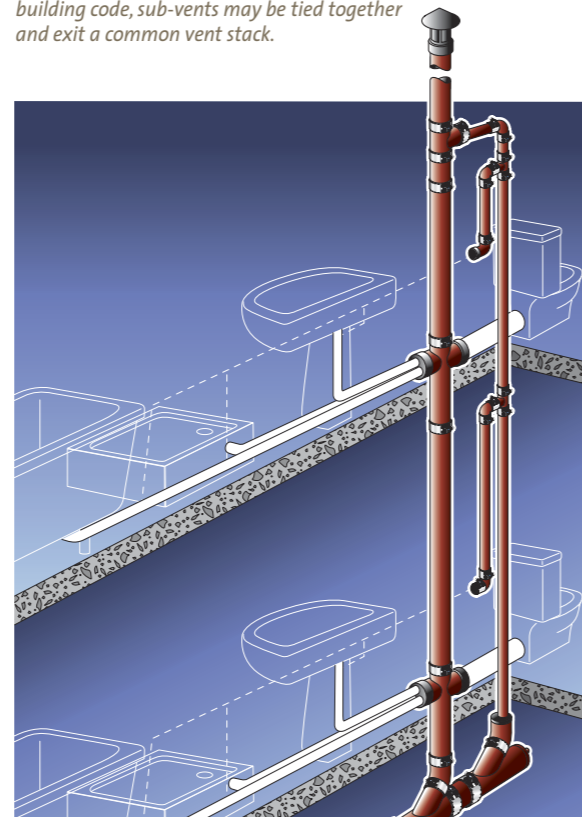

## Roof penetration device

To secure roof watertightness, which is of crucial importance, the number of roof penetrations should be limited. SAINT-GOBAIN PAM has designed for its pipe systems, a roof penetration device that is watertight and quick to install.

The system was developed to ease installation of perfectly watertight roof penetration for cast iron primary ventilation pipes or vent pipes. The flanged fittings clamp both the vapour barrier and the waterproofing layer.



The roof penetration device is a set of two ductile iron flanged fittings – one of the flanges is fixed, the second is movable - equipped with rubber gaskets.

Rubber gaskets are available in EPDM or NBR quality where hydrocarbons can be feared.

*See product codes p 45*

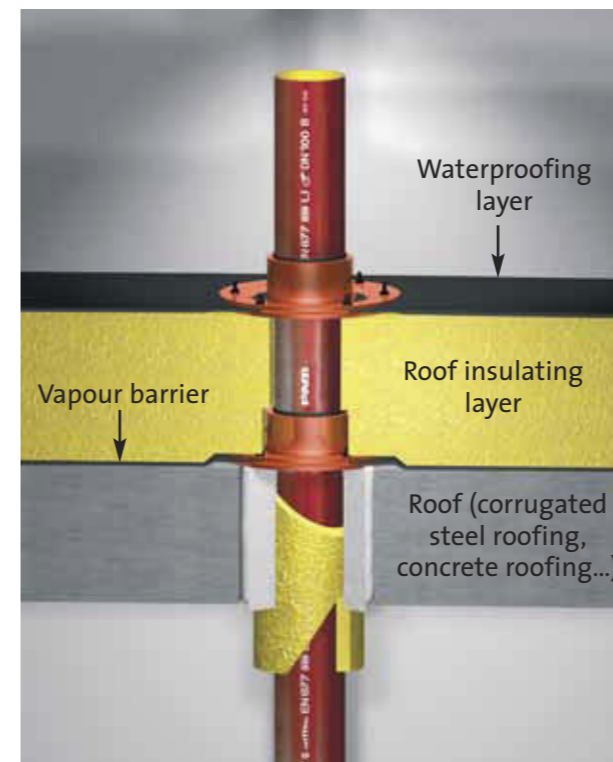

The first flange fitting, installed above the roof clamps the vapour barrier under the roof insulating layer, the second, above the insulating layer clamps the waterproofing layer, be it polymer or bituminous.

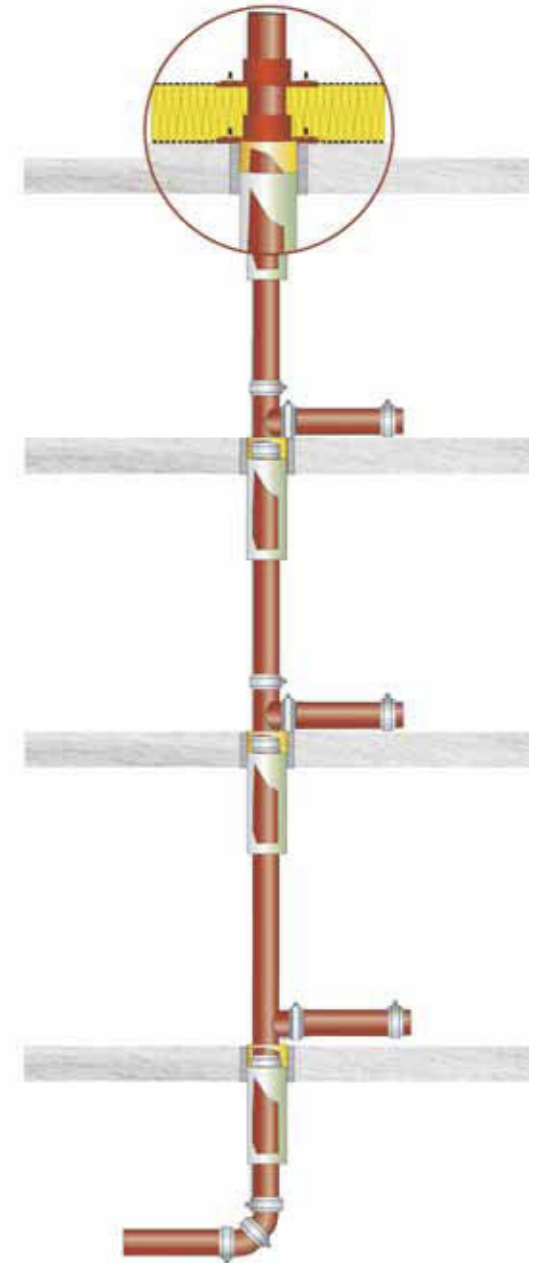

# Design recommendations

## Multi waste manifold

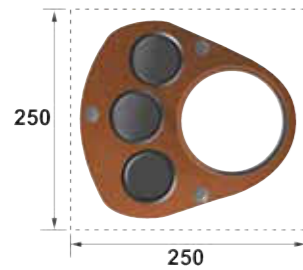

The multi-waste manifold simplifies waste plumbing by grouping all associated pipework from various sources such as sinks, basins, bidets, urinals and showers to one internal point above the finished floor level.

The manifold will permit the connection of three 32/38mm copper/plastic waste inlets to any new or existing 100mm diameter PAM SMU / Ensign pipe stack and three 50mm copper/plastic waste inlets to 150mm diameter pipe stack.

The manifold main body is connected to the stack using standard couplings. On the 100mm manifold to achieve a 32mm waste connection, remove the inner rubber ring, 38mm utilising the outer ring (for waste pipe maximum lengths see EN 12056-2). Pipework connecting discharge appliances to the manifold, should be designed not to cause self siphonage.

### Fixing instructions

1. Remove grommets, pierce the appropriate groove for 32mm or 38mm waste (100mm manifold only) connections and tear out centre disc where required.
2. Apply an appropriate silicone grease (not provided) to the outside of the grommet and re-fit into manifold ensuring that the retaining groove of the grommet is located correctly in the casing.
3. Lubricate pipe ends and insert into grommet with a rotational movement. Pipe ends may be chamfered for ease of insertion.
4. Any grommet not fitted with a waste pipe must also follow instruction 2 above.



### Typical manifold installation



The new EEZI-FIT manifold can be used to make a vent stack when one of the outlet is available. The drawing below shows two possible methods, both of which were successfully used in the past.

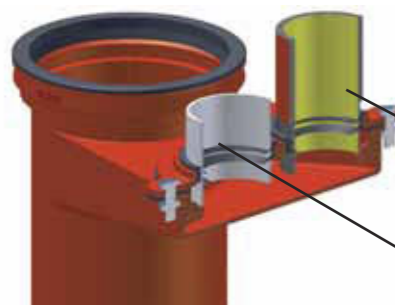

On the right, a short length of 50mm Ensign/SMU pipe, turned down to 56mm OD pushed into the manifold and coupled onto in Ensign or SMU using standard couplings.

Secondly, on the left, a length of 56mm PVC, HDPE or PP pushed into the manifold to facilitate venting of the stack.

For further details, consult our Technical Department

## Single stack branch

The CEBTP branch is a patented device made to allow wastewater drainage without vent pipes.

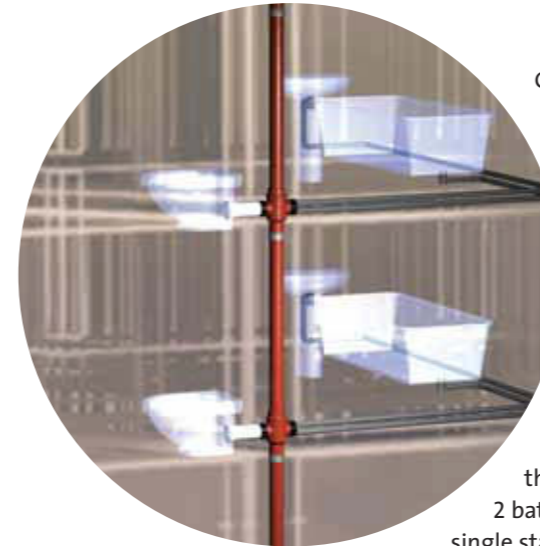
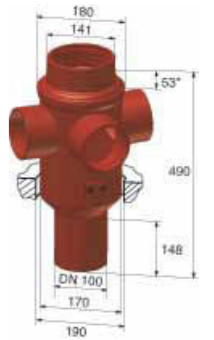

Given that the maximum number of connected sanitary appliances is respected, the single stack branch CEBTP properly drains waste water in a single stack, without vent pipes, whilst limiting the risks of self siphonage.

This device complies with the Regulation in force and with Standard EN 12056.

Consult local requirements for compliance.

### Field of use:

- Multi connection of sanitary appliances for adjacent flats, or sanitary blocks
- Compactness when the space is limited
- No secondary vent pipes being required.

### Drivers:

It simplifies plumbing by grouping the pipeworks from 3 or 4 times more sources than a conventional installation. Maximum connections for each floor level: 2 toilets, 2 bathtubs and all the usual sanitary facilities for two flats (sinks, basins, showers...). The single stack branch is particularly suitable for narrow service shafts, for hotel rooms, student flats or any other building with adjacent sanitary blocks.

### Operation features

-Prevents excessive pressure variations in the stack system.

-Limits negative pressure by optimal venting and prevent self siphonage.

The single stack branch DN 100 main body is connected to the stack using standard couplings and a traditional jointing method. Their water tightness is ensured by the rubber gaskets which equip the SMU® S, SME and SMU® Plus product lines, proposed by SAINT-GOBAIN PAM.

The plumbing works overall shall be executed in compliance with standard EN 12056: the appliances are to be installed with traps in compliance with the specifications of the same standard.

### Products:

The single stack Branch now exists in long tail to allow connection to the main stack under the slab and thus ease installation either in new or renovation works.

- Three different products, 2 or 3 inlets:
- Corner branch two inlets 88°
  - Double branch two inlets 88°
  - A consecutive branch, three inlets 88°

Rubber plugs with several pre-cut lids will permit from one to three different connections.

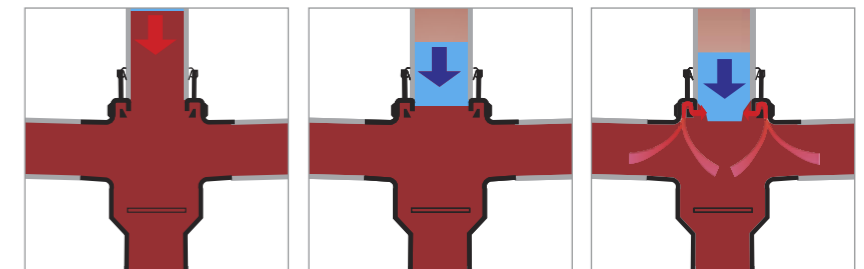

Owing to the special design of the branch, after a flush, the column of water is directed so that air can pass over the flow and naturally vent the stack.

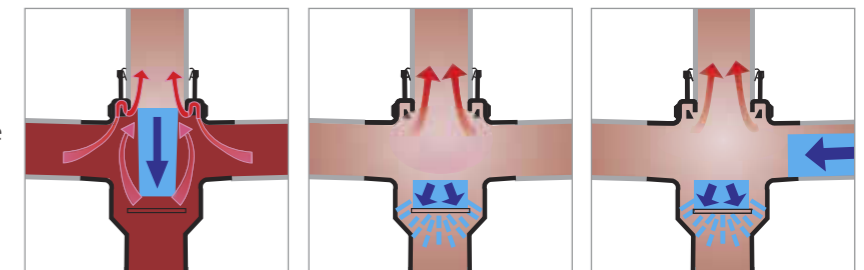

Inside the branch, at the bottom of the body, a rubber deflector sprays the column of water to prevent draught or self siphonage.

# Design recommendations

## Pipeworks stability

### Stack support pipe for open hoppers.

A pipework is submitted to different forces liable to affect its stability. Stack supports are cast iron components designed to address these efforts when a stack is installed through open hoppers.



On straight runs, stack support pipes should be installed to address the pipes weight. At the bottom of the stack, the first stack support pipe addresses both pipes weight and end thrust effort. For the last case, it is recommended that the support and fixings should be adapted accordingly.

We recommend to position the first stack support pipe at the base of the first floor, and then every subsequent fifth floor, in case of a standard average 2.5 m between floors, or more generally every 15 m.

In case of closed hopper, no stack support pipe is required.



### Stack support pipe and acoustic insulation

The support bracket covered with rubber gasket prevents the structure-borne noise from the drainage network from radiating at the slab level.

Rubber gasket

### Stack support pipe installed vertically

Either on cantilever arms or stack support consoles for DN 100.

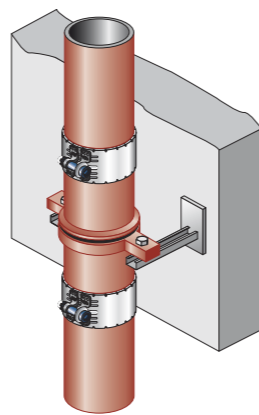

### Stack support pipe installed horizontally

Wall bracketing system in mild steel, for use with stack support pipes and brackets, is available.

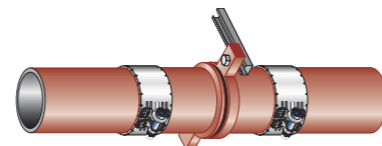

## Access to the pipework

Access to the pipework must be ensured so that tests, inspections and maintenance can be performed. Access may be obtained using a short access pipe.

### On downpipes

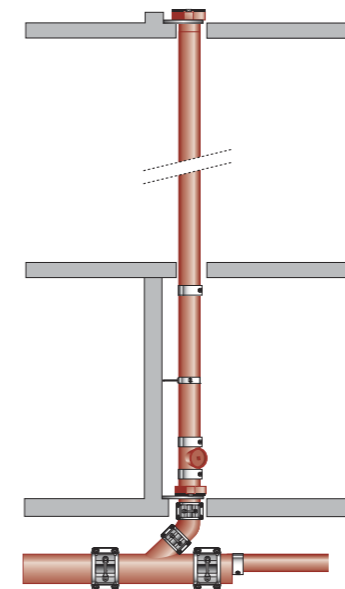

At the bottom of the stack

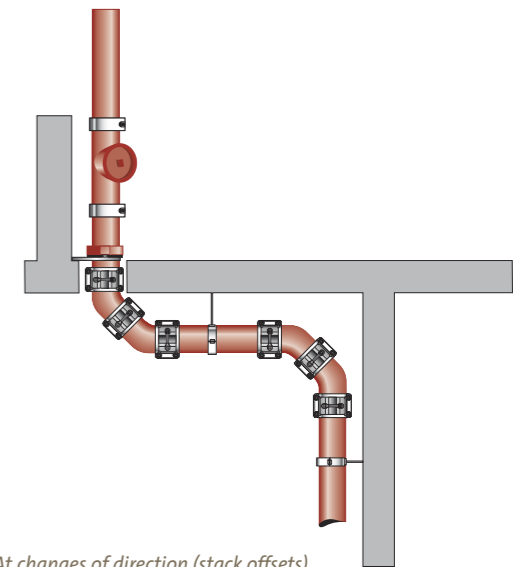

At changes of direction (stack offsets).

### On horizontal collectors

On horizontal runs, the short access pipe will be installed in a slightly sloped position with respect to the pipe crown.

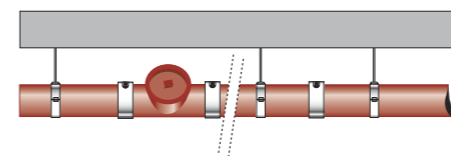

## Water flow and air circulation, according to the standard 12056-2 & 12056-3.

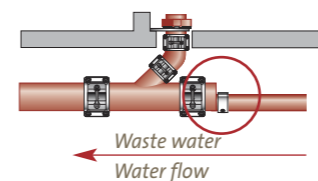

The internal diameter of pipes cannot be reduced in the direction of the water flow, except in the case of pipeworks operating at full bore, under negative pressure such as in the siphonic roof drainage system EPAMS.

The addition of branch connections, or changes of fall liable to increase the water flow rate, may require an increase of internal pipe diameter. This increase can be made upstream of the new branch connection, using a tapered pipe reducer (see page 42).

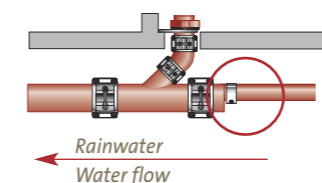

### Rainwater horizontal pipelines

In horizontal and near horizontal pipelines, increases in size shall be installed such that the soffit is continuous in order to prevent air from being trapped.

# Design recommendations

## Bracketing: technical

### Pipe support except for the EPAMS system

For cast iron, the bracketing system is designed to only carry the weight of the pipe and its content, which makes the specifiers' design work easier.

#### Pipe weight in kg per metre.

	40	50	75	100	125	150	200	250	300	400	500	600
Empty pipe	3	4	6	8	11	14	22	32	42	60	82	107
Full pipe	4	6	11	16	24	31	54	82	113	185	278	390

Note: The technical specifications for threaded rods and metal brackets shall be established on this basis.

### Bracketing recommendations for cast iron pipe system elements

		Number of brackets	
Vertical run	Pipes	1 (2)*	
	Fittings**	1	
Horizontal run	Pipe length > 2m	2	
	Pipe length < 2m	1	
	Fittings**	1	

*Consult local requirements for compliance.*

*\* for SMU pipes L > 2,7 m installed outdoor.*  
*\*\* when the shape of the fitting permits*

It is also recommended to use one bracket per length or fitting (when the shape allows it, i.e. branches...)

#### Support for horizontal pipework

The general recommendation for horizontal pipework is two load bearing brackets per pipe. For an indication, they should be installed at 0.75 m from each spigot so that, ideally, the distance between two brackets should be 1.5m. Installation shall respect a slight fall, around 1 or 2%, and 0.5% at a minimum, (0.5 cm per metre).

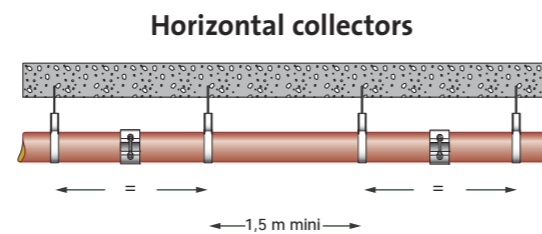

#### Support for vertical pipework

For vertical waste or rainwater stacks, the brackets aim at preventing the pipework to fall over. It is recommended that one bracket should be fitted for each floor level.

Ideally the bracket should be installed on the first third from the upper spigot, and even closer to a socket joint.

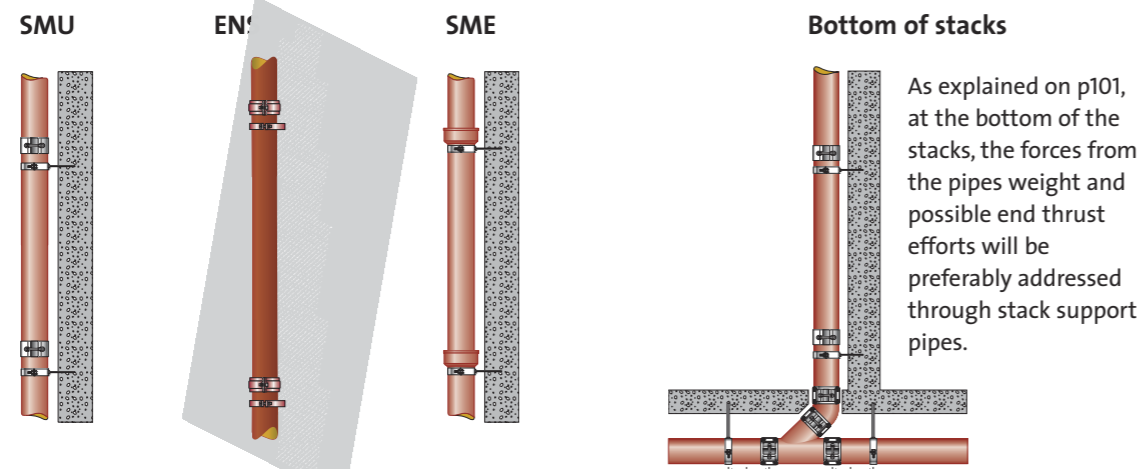

Bracketing installations, openings and sealings are prohibited in prestressed girders.

## ENSIGN pipe systems and ductile iron brackets.



### Pipe support bracket

The unique, all-purpose, lightweight, ductile iron bracket incorporates an elongated slot at the fixing point. This allows both vertical and lateral adjustment without dismantling the pipe system.



#### Typical support arrangement for vertical pipework

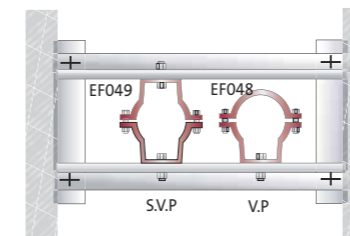

#### Typical support arrangement for horizontal pipework

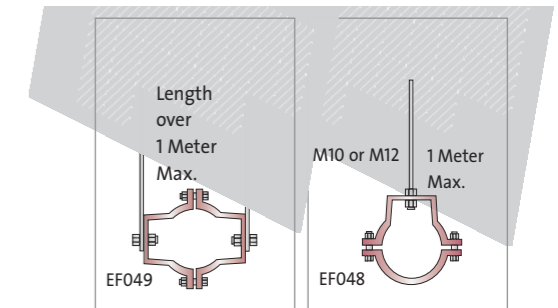

### Push fit joint coupling

This iron coupling with fixing ears does both jointing and bracketing.

Installation:

1. Apply a small amount of lubricant on the lip of the rubber gaskets, both ends, to ease insertion of pipe/fittings.

2. Push joint over the end of pipe/fitting, ensuring the central register is abutted against the spigot edge evenly. Fix to wall using anti-corrosion coach screws or similar.

3. Push the second pipe or fitting into the gasket again ensuring that the spigot is abutted against the central register. Eared joints can be fitted to most fittings within the SMU- ENSIGN 50, 70, 100 and 150 mm diameter ranges. Bolts should be tightened until a suitable resistance is achieved.



# Design recommendations

## Specific Bracketing for acoustic insulation

The evacuation of waste, soil and rainwater generates structure-borne and airborne sound between rooms and usually occurs as the result of a mixed flow, when the pipe is filled with water and air. In such circumstances a pipe will radiate noise outwards and transfer it to any lightweight ceilings, cupboards and similar areas wherever it makes contact.

### PAM Acoustic dampener

All brackets within the SAINT-GOBAIN PAM range meet the requirements of the most demanding standards. For exceptionally high levels of acoustic performance, the standard ductile iron or steel brackets fitted with a new acoustic dampener should be used. The different assemblies have been tested to EN14366: Laboratory measurements of noise from waste water installations.

The PAM acoustic dampener has been developed to meet the increasing demand for buildings which require a high level of acoustic performance over regulations requirements.



PAM pipe installation fitted with acoustic dampener\*  
Structure-borne noise: 2l/s = 5 dB - 4l/s = 11 dB  
\* IPB results, November 2006 installation according to EN 14366

#### Material:



1. Dampener –elastomer EPDM
2. M8-M10 nut – galvanised bichromated steel
3. Retainer cup – AISI 304 stainless steel
4. Small dish – AISI 304 stainless steel
5. M8-M10 tapped base - galvanised bichromated steel

## Acoustic bracket installation

### Vertical

For vertical pipe stack: one acoustic bracket minimum per 3 metres

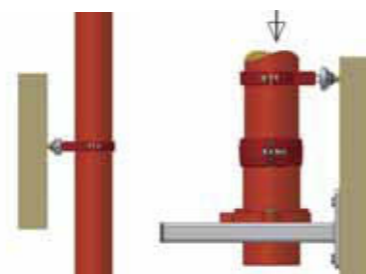

The combination of stack support bracket with rubber gasket and PAM Acoustic considerably dampens structure-borne noise.

### Horizontal

Horizontal suspended pipework: two acoustic brackets minimum per 3 metres.

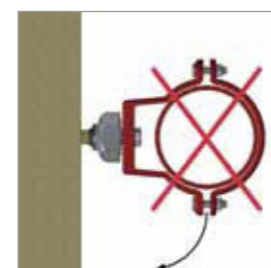

Horizontal pipework: fixing brackets on side as per diagram is not recommended. This will lead to product failure

## Cast iron protection: additional coating or overpainting

FAQ



### Do cast iron pipes need to be overpainted before installation?

The acrylic paint on the pipes is a primer which can be over painted with most top coats. Finish paint is necessary where the pipeworks are visible, indoor or outdoor. What types of paint can be used? Any alkyd resin, or glycerophthalic paint dedicated to metal care and suitable for the requirements of the local environment.

The system should be gently rubbed down with suitable abrasive paper, in order to provide a good adhesion key for the finish coating. Where the finish paint should be used on zinc coated pipes to rejuvenate them, rub them down gently to remove possible zinc salts.

Where incipient rust has already appeared on cast iron products, corrosion inhibitors can be used before painting. Some existing metal finishes including anti-corrosive pigment can be applied directly to rust.

## Condensation on drainage pipework

Condensation may appear whenever the temperature of the drainage pipes walls is lower than the dew point. This happens when the temperature of the fluid transported is much lower than that of the surrounding atmosphere and when the hygrometry level is high.

Possible local regulation or preventive solutions fall within the competence of the engineering and design department, after taking the building project specificities into account. According to the anticipated results and the requirements as regards fire protection of the building, solutions such as mineral wool, anti-condensation painting or finally, insulating strip can be considered.



## Aggressive atmospheres

Pipes and fittings installed within an aggressive chlorine environment (swimming-pools) should be over-painted with a special air dry epoxy coating. Please refer to paint manufacturers to select the appropriate product to resist this specific stress.

In such atmosphere all stainless steel couplings are compulsory.

## Aggressive soil conditions

According to Annex C of EN 877, for pipes buried in contact with soils with a lower pH than 6, it is recommended they should be additionally protected with polyethylene sleeve or any other type of external coating as appropriate.



# Design recommendations

## Buried pipe systems

The SMU - Ensign Plus pipes can be used in below ground applications. Buried pipes are subject to mechanical strain due to the weight of grounds and possibly wheel loading when they are laid under a circulating area.

The mechanical performance of a buried pipework is to be considered as a pipe/ soil system: the interaction of the pipes with the surrounding soils depends on their stiffness or flexibility, and the selected type of laying condition.

The choice of bedding and backfilling depends on the depth at which the pipes have to be laid, the size and the strength of the pipes. The standard EN 1610 "Construction and testing of drains and sewers" applies to drains normally buried in the ground and normally operating under gravity.

You will find below the hypothesis for rigid pipes retained for the calculation of allowable depth of cover.

DN 100 to DN 300	
Modulus of Young :	110000 N/mm <sup>2</sup>
Poisson's ratio :	0.25
Max. stress :	350 N/mm <sup>2</sup>
Strain coefficient :	1.5
Buckling Coefficient :	2.5
Geometrical defect :	1,2 + DN/2000 mm



Installation parameters are laid down according to:

- Soil type (see groups below)
- Quality of compaction of the embedment
- Behaviour of the pipe (rigid for cast iron)
- Presence of wheel loads or not
- Particular conditions (groundwater table...)

## Backfilling recommendations from DN 100 to DN 300, with or without traffic loads (according to EN 1610).

Two main solutions have been retained out of the EN 1610 recommendations, taking into account both ease of installation and knowledge from experience of rigid pipe systems. For compaction, the more adverse hypothesis was retained.

These solutions maximise the advantage from cast iron's mechanical properties: depth of cover they can withstand, possible backfilling with native soil removed, thereby limiting the damage to the environment...

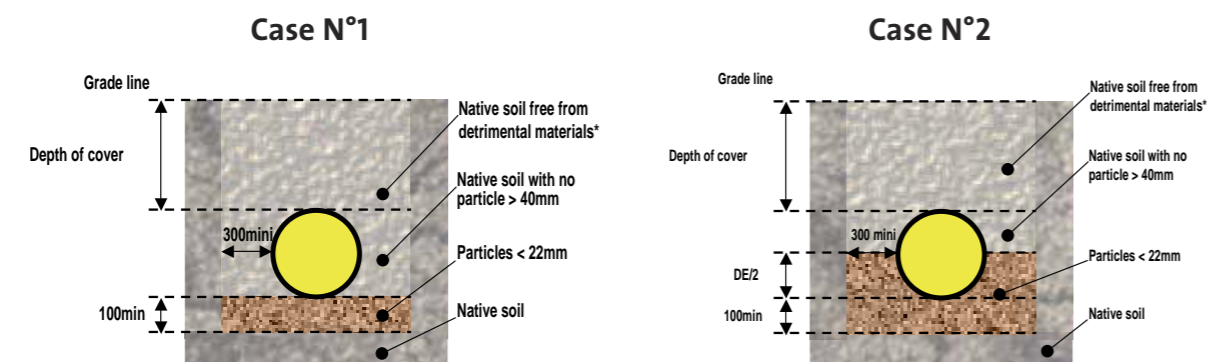

Dimensions are in mm

\* Detrimental materials = stones; tree roots; rubbish; organic material; clay lumps (>75 mm); snow and ice.

From our experience in buried pipe systems and the French origin of our company, we have retained French Fascicule 70 calculation model (recommendations for sewage pipe systems according to the pipe material).

The table below gives values for depths of covers according to the Fascicule 70 calculation, considering rigid pipes.

		Depth of cover values (m)	
		Without traffic loads	With traffic loads
Solution 1	Mini**	0,3(1)	1
	Maxi	3,2	2,4
Solution 2	Mini**	0,3(1)	0,3
	Maxi	6 (or 9)	6 (or 9)

\*\* does not take into account the frost free arrangements

(1) The calculation allows shallower depth of cover, but this figure includes safety margin / ground surface proximity and related hazards.



### Other precautions:

- Clearance at each joint between the couplings and the granular bed to allow sufficient space and to prevent the pipe from resting on the joints. (see EN1610 §8.5.4)
- Testing for pipe system leak tightness according to EN 1610 §13.
- Identification of the pipework with a netting for example.
- Furthermore, check that these specifications do not contravene to other local or national regulation or recommendations for installation.

**For any other case, other diameters or buried systems under the bottom slab, please refer to the technical support.**

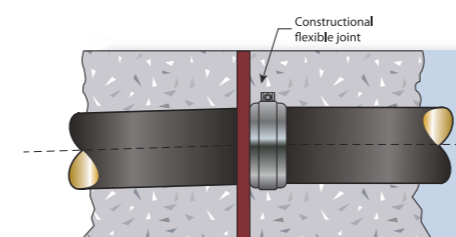

## Systems embedded in concrete

Where SMU-Ensign pipe system is to be set in concrete, a minimum 2.5 cm width of concrete on every side has to be respected because during its curing and after, the concrete will be subject to shrinkage and carbonation.

To reduce the natural rigidity of the concrete and its strain, a suitable flexible joint can be installed at intervals. This could be made of a compressible material (eg. expanded polystyrene) be placed next to a pipe joint, and conform to the full cross section of the concrete. (See Fig). Refer to local good practice.

Furthermore, the pipe system should not be in contact with the metallic reinforcements of the concrete.

Surround should not be carried out until the pipework has been tested and inspected.



FAQ

# Design recommendations

## EPAMS syphonic roof drainage pipeworks

An EPAMS pipework consists of one or several horizontal pipes without fall connected to a downpipe: horizontal runs and stacks are made of ENSIGN- SMU 5 cast iron components. The joints are generally made with SMU Rapid 2 or equivalent couplings able to withstand a negative pressure of -900 mbar.

### Connections of the roof outlets to the pipe system:

Depending on the jobsite constraints, the connection can be made flat or vertical.

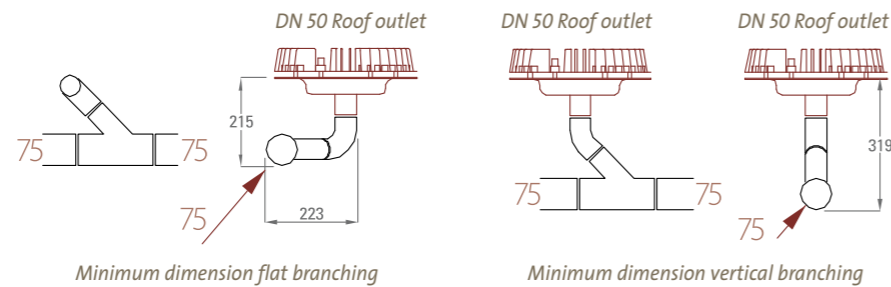

### Decompression zone:

Before connecting to the sewer main syphonic systems have to run by gravity again.

#### EPAMS design

At the end of the downpipe, the bottom pipe increases in diameter –generally two extra diameters – causing decompression and reducing the flow velocity.

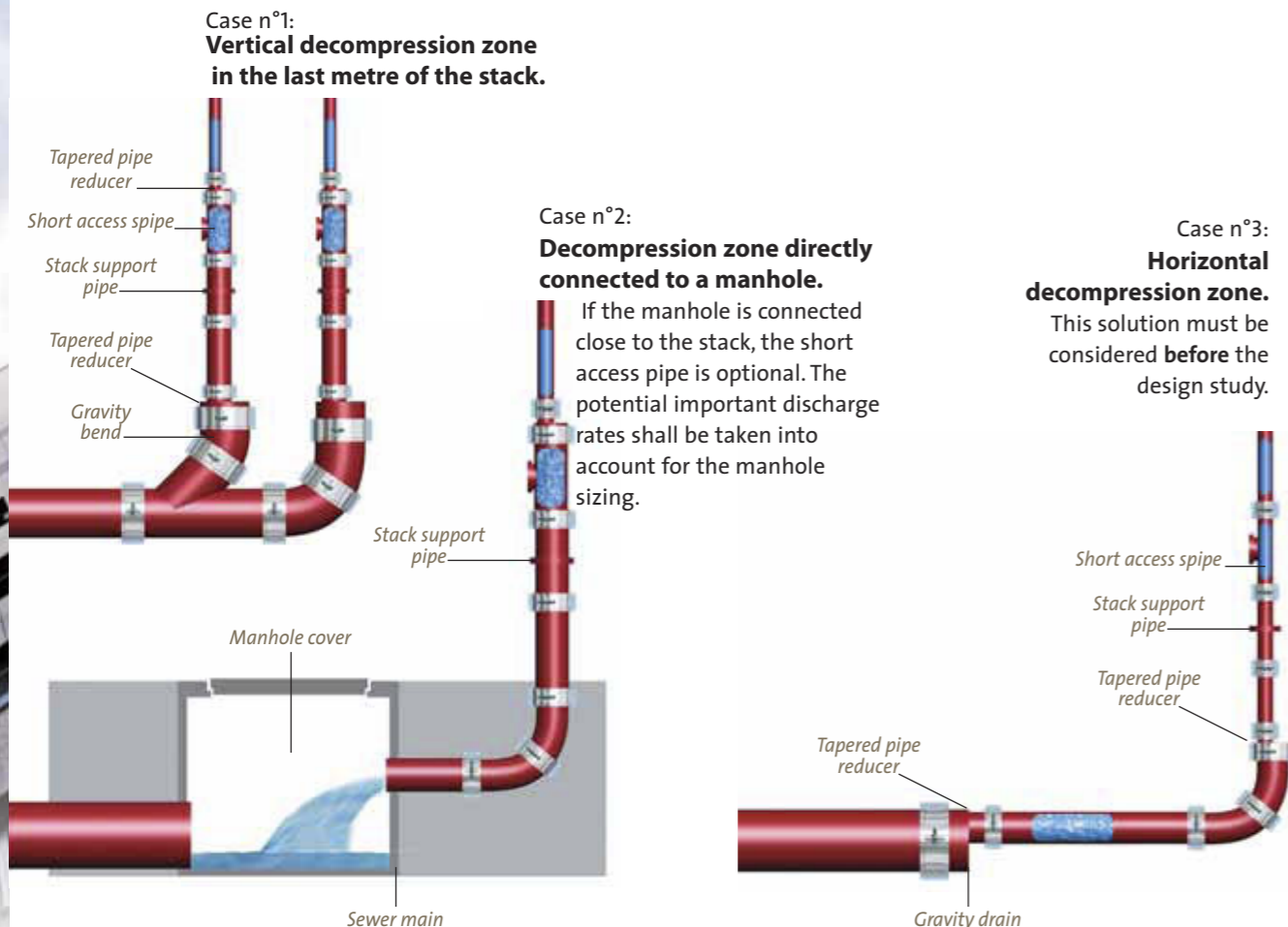

### Pipe support

Stack support pipes are installed at the bottom of stacks to address forces due to changes in the streamflow regimes.

Every 15 metre is the general requirements.

### Pipe brackets

Because of high discharge rates, rubber lined steel brackets are compulsory.

## Specific points of the network:

### Gripped couplings

On EPAMS pipeworks, grips collars are specified on couplings where they shall withstand dislocation forces.

- **Horizontal pipe connected to the outlet** when expected pressure is over 0.5 bar or -0.5 bar.
- The negative pressure will be at the highest at the **head of the stack** (down to - 0.9 bar); the couplings will be there systematically installed with grip collars.
- **Change of direction:** in changes of direction on stacks and low collectors, the couplings will be gripped. Where a change of direction will be added or removed, SAINT-GOBAIN PAM will carry out a new study taking the new head loss into account.
- **The decompression zone** is subject to high turbulences, and subsequently, every component at the bottom of the stack, before the return to gravity flow regime, shall be gripped.

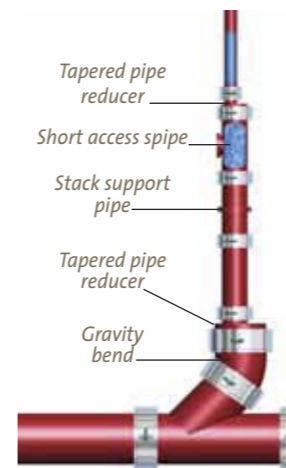

All the gripped component are specified in the isometries of the design study.

### Reduction of flow sections

Seeking balance of potential energy and head losses on the pipework can call for reduction of the nominal diameters to increase head losses.

By regulation, the reduction of nominal diameter (DN) of discharge pipes is prohibited in the direction of flow except for syphonic systems like EPAMS (EN 12056-3 § 7,6,5) where it could be useful to control the pressure level.

Increase and reduction of nominal diameters are made with the tapered pipe reducer.

On horizontal runs, the pipe reducer will be installed so that the pipe invert is continuous.

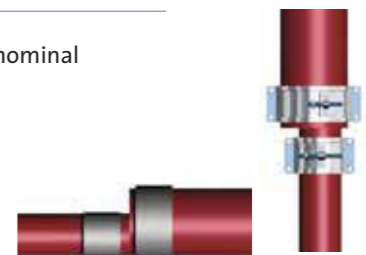

## EN 877:1999 + Amendment / A1: 2006 + Corrigendum / AC: 2008

**Cast iron pipes and fittings, their joints and accessories for the evacuation of water from buildings – Requirements, test methods and quality assurance.**

### Scope:

This European Product Standard applies to cast iron pipework elements used for the construction, normally as gravity pipe systems, of discharge systems for buildings and of drains. The range of nominal diameters extends from DN40 to DN600 inclusive. This standard specifies the requirements for the materials, dimensions and tolerances, mechanical properties, appearance and standard coatings for cast iron pipes, fittings and accessories. It also indicates performance specifications for all components, including joints. It covers, above ground soil, waste, rainwater and buried systems and performance requirements in these applications.

### The concerned ranges:

PAM-SMU S and Plus, PAM-ENSIGN S and Plus: DN 40 to 600

Rainwater range: DN 75 to 150

Socket pipe system SME: DN 50 to 150

The EEZI-FIT socket fittings have been included in Kitemark certificate KM51733 for sanitary gravity applications and 0.5 bar (accidental static water pressure) performance: DN 100 and 150.

### Definitions:

**Discharge system for buildings:** system of pipes, fittings, accessories and joints used to collect and drain waste water and rainwater from a building; it comprises discharge pipes, ventilation stacks and rainwater pipes, installed within the limits of a building or attached to the building.

**Drain:** system of pipes, fittings, accessories and joints installed outside the limits of a building in order to connect the discharge system of this building to a soil and drain or a septic tank.

**Sewer:** system of pipes designed to collect waste water and rainwater from buildings and surface water and to convey them to the point of disposal or treatment.

### Requirements:

**Adhesion** see 4.6

**Hot water resistance:** 24 H at 95°C and thermal cycles (1500 cycles of 1min between 15 and 93°C)

**Salt spray resistance:** 350 h

**Chemical resistance:** 2 >pH > 12 at 23°C

To test the chemical resistance of cast iron products standard EN 877 defines that product samples shall be immersed - for 30 days and held at (23 + 3)°C, the pH being constantly monitored - in the following test liquids:

- a solution of sulfuric acid at pH 2, for the first sample;
- a solution of sodium hydroxide at pH 12, for the second sample.
- a solution of waste water at pH 7 for the third sample.

**Dimensions - External diameter (DE)** see 4.2.2

**Coatings for pipes and fittings: general** see 4.6

Specific requirements for coatings for buried systems and rainwater systems installed outside buildings are given in 4.8.3 and 4.9.2 respectively.

**Water tightness** Joints water tightness – Performance requirements see 4.7.5

**Reaction to fire** see EN 877:1999/A1:2006/AC -4.6.3 External coatings and 5.7.3.3

**Noise protection** see EN 877:1999/A1 - 4.1.4

## CE Marking

(see Section 1 p 21)

**To allow free circulation of industrial products within the European Union, while guaranteeing the safety of European consumers and users of the products, construction products must meet essential requirements covering public health, safety and consumer protection.**

Based on EN 877, CE marking became mandatory on cast iron wastewater products leaving the European factory, from 2009 September the 1<sup>st</sup>.

Do not hesitate to compare the reaction to fire classifications of the materials you specify.

**Remember that CE marking is not a Quality mark or label.** Its scope is limited to **health and operation safety**. It is intended mainly for the authorities in charge of market control.

## Product standards and Quality marks

Standard EN 877, which defines the requirements for cast iron wastewater pipe systems, is a self-declared standard. This means that the manufacturer is allowed to self declare that his product complies with this standard except for reaction to fire classification of the range which requires an initial type test by a notified test laboratory.

## Quality Marks, proof of conformity with EN 877

**Voluntary Quality marks** aim at fitness for purpose. They add value to the product in terms of customer-supplier relationships.

Only compliance with EN 877 that is **validated by a third party for all criteria, and periodically tested**, can guarantee the performance of the systems you specify.

Look for cast iron products fully complying with EN 877, bearing a quality mark, such as a Kitemark, NF or Watermark for example, being delivered by an accredited certification body.

**BS EN 877:1999 Kitemark KM51733**



Ensign (S and Plus) is the only cast iron system to be tested and awarded Kitemark approval to the product standard in the UK.

Ensign EEZI-FIT has been included in the Kitemark certificate KM51733 for sanitary gravity applications and 0.5 bar (accidental static water pressure) performance.

**NF EN 877:1999 NF**



**SMU S and Plus ranges, SME**

**EN 12056**

### Gravity drainage systems inside buildings

It covers waste water drainage systems which operate under gravity. It is applicable for drainage systems inside dwellings, commercial, institutional and industrial buildings and sets out principles to be followed for both layout and calculation. It makes limited provision for drainage systems conveying trade effluent and also makes limited provision for fluids removed by pumps.

Differences in plumbing within Europe have led to a variety of systems being developed. Some of the major systems in use are described in this standard.

Part 1: General and performance requirements.

Part 2: Sanitary pipework, layout and calculation.

Part 3: Roof drainage, layout and calculation.

Part 4: Wastewater lifting plants - Layout and calculation.

Part 5: Installation and testing, instructions for operation, maintenance and use.

# Design data

Discharge capability of PAM S pipes according to EN 877 and DIN 19522

Filling level 50 % (h/d=0.5)

J cm/m	DN 70 d <sub>i</sub> = 71		DN 75 d <sub>i</sub> = 75		DN 100 d <sub>i</sub> = 103		DN 125 d <sub>i</sub> = 127		DN 150 d <sub>i</sub> = 152		DN 200 d <sub>i</sub> = 200		DN 250 d <sub>i</sub> = 263		DN 300 d <sub>i</sub> = 314	
	Q l/s	v m/s	Q l/s	v m/s	Q l/s	v m/s	Q l/s	v m/s	Q l/s	v m/s	Q l/s	v m/s	Q l/s	v m/s	Q l/s	v m/s
0.5	0.8	0.4	0.9	0.4	2.1	0.5	3.7	0.6	6.0	0.7	12.5	0.8	25.8	1.0	41.3	1.1
0.6	0.9	0.4	1.0	0.4	2.3	0.6	4.1	0.6	6.6	0.7	13.7	0.9	28.3	1.0	45.3	1.2
0.7	0.9	0.5	1.1	0.5	2.5	0.6	4.4	0.7	7.1	0.8	14.8	0.9	30.6	1.1	48.9	1.3
0.8	1.0	0.5	1.1	0.5	2.7	0.6	4.7	0.7	7.6	0.8	15.8	1.0	32.7	1.2	52.3	1.4
0.9	1.1	0.5	1.2	0.6	2.9	0.7	5.0	0.8	8.1	0.9	16.8	1.1	34.7	1.3	55.5	1.4
1.0	1.1	0.6	1.3	0.6	3.0	0.7	5.3	0.8	8.5	0.9	17.7	1.1	36.6	1.3	58.5	1.5
1.1	1.2	0.6	1.4	0.6	3.2	0.8	5.5	0.9	8.9	1.0	18.6	1.2	38.4	1.4	61.4	1.6
1.2	1.2	0.6	1.4	0.6	3.3	0.8	5.8	0.9	9.4	1.0	19.4	1.2	40.1	1.5	64.2	1.7
1.3	1.3	0.6	1.5	0.7	3.4	0.8	6.0	1.0	9.7	1.1	20.2	1.3	41.8	1.5	66.8	1.7
1.4	1.3	0.7	1.5	0.7	3.6	0.9	6.3	1.0	10.1	1.1	21.0	1.3	43.4	1.6	69.3	1.8
1.5	1.4	0.7	1.6	0.7	3.7	0.9	6.5	1.0	10.5	1.2	21.7	1.4	44.9	1.7	71.8	1.9
1.6	1.4	0.7	1.6	0.7	3.8	0.9	6.7	1.1	10.8	1.2	22.4	1.4	46.4	1.7	74.1	1.9
1.7	1.5	0.7	1.7	0.8	3.9	0.9	6.9	1.1	11.1	1.2	23.1	1.5	47.8	1.8	76.4	2.0
1.8	1.5	0.8	1.7	0.8	4.1	1.0	7.1	1.1	11.5	1.3	23.8	1.5	49.2	1.8	78.7	2.0
1.9	1.5	0.8	1.8	0.8	4.2	1.0	7.3	1.2	11.8	1.3	24.5	1.6	50.6	1.9	80.8	2.1
2.0	1.6	0.8	1.8	0.8	4.3	1.0	7.5	1.2	12.1	1.3	25.1	1.6	51.9	1.9	82.9	2.1
2.5	1.8	0.9	2.0	0.9	4.8	1.2	8.4	1.3	13.5	1.5	28.1	1.8	58.0	2.1	92.8	2.4
3.0	1.9	1.0	2.2	1.0	5.3	1.3	9.2	1.5	14.8	1.6	30.8	2.0	63.6	2.3	101.7	2.6

Filling level 70 % (h/d=0.7)

J cm/m	DN 70 d <sub>i</sub> = 71		DN 75 d <sub>i</sub> = 75		DN 100 d <sub>i</sub> = 103		DN 125 d <sub>i</sub> = 127		DN 150 d <sub>i</sub> = 152		DN 200 d <sub>i</sub> = 200		DN 250 d <sub>i</sub> = 263		DN 300 d <sub>i</sub> = 314	
	Q l/s	v m/s	Q l/s	v m/s	Q l/s	v m/s	Q l/s	v m/s	Q l/s	v m/s	Q l/s	v m/s	Q l/s	v m/s	Q l/s	v m/s
0.5	1.3	0.4	1.5	0.5	3.6	0.6	6.2	0.7	10.1	0.7	20.8	0.9	43.1	1.1	68.9	1.2
0.6	1.4	0.5	1.7	0.5	3.9	0.6	6.8	0.7	11.0	0.8	22.9	1.0	47.2	1.2	75.5	1.3
0.7	1.6	0.5	1.8	0.5	4.2	0.7	7.4	0.8	11.9	0.9	24.7	1.1	51.1	1.3	81.6	1.4
0.8	1.7	0.6	1.9	0.6	4.5	0.7	7.9	0.8	12.7	0.9	26.4	1.1	54.6	1.3	87.3	1.5
0.9	1.8	0.6	2.1	0.6	4.8	0.8	8.4	0.9	13.5	1.0	28.1	1.2	58.0	1.4	92.6	1.6
1.0	1.9	0.6	2.2	0.7	5.1	0.8	8.8	0.9	14.3	1.1	29.6	1.3	61.1	1.5	97.6	1.7
1.1	2.0	0.7	2.3	0.7	5.3	0.9	9.3	1.0	15.0	1.1	31.0	1.3	64.1	1.6	102.4	1.8
1.2	2.0	0.7	2.4	0.7	5.5	0.9	9.7	1.0	15.6	1.2	32.4	1.4	67.0	1.6	107.0	1.8
1.3	2.1	0.7	2.5	0.7	5.8	0.9	10.1	1.1	16.3	1.2	33.8	1.4	69.7	1.7	111.4	1.9
1.4	2.2	0.7	2.6	0.8	6.0	1.0	10.5	1.1	16.9	1.2	35.0	1.5	72.4	1.8	115.6	2.0
1.5	2.3	0.8	2.7	0.8	6.2	1.0	10.9	1.1	17.5	1.3	36.3	1.5	74.9	1.8	119.7	2.1
1.6	2.4	0.8	2.7	0.8	6.4	1.0	11.2	1.2	18.1	1.3	37.5	1.6	77.4	1.9	123.7	2.1
1.7	2.4	0.8	2.8	0.9	6.6	1.1	11.6	1.2	18.6	1.4	38.6	1.6	79.8	2.0	127.5	2.2
1.8	2.5	0.8	2.9	0.9	6.8	1.1	11.9	1.3	19.2	1.4	39.8	1.7	82.1	2.0	131.2	2.3
1.9	2.6	0.9	3.0	0.9	7.0	1.1	12.2	1.3	19.7	1.5	40.9	1.7	84.4	2.1	134.8	2.3
2.0	2.7	0.9	3.1	0.9	7.2	1.2	12.5	1.3	20.2	1.5	41.9	1.8	86.6	2.1	138.3	2.4
2.5	3.0	1.0	3.4	1.0	8.0	1.3	14.0	1.5	22.6	1.7	46.9	2.0	96.9	2.4	154.7	2.7
3.0	3.3	1.1	3.8	1.1	8.8	1.4	15.4	1.6	24.8	1.8	51.4	2.2	106.1	2.6	169.6	2.9

Filling level 100 % (h/d=1.0)

J cm/m	DN 70 d <sub>i</sub> = 71		DN 75 d <sub>i</sub> = 75		DN 100 d <sub>i</sub> = 103		DN 125 d <sub>i</sub> = 127		DN 150 d <sub>i</sub> = 152		DN 200 d <sub>i</sub> = 200		DN 250 d <sub>i</sub> = 263		DN 300 d <sub>i</sub> = 314	
	Q l/s	v m/s	Q l/s	v m/s	Q l/s	v m/s	Q l/s	v m/s	Q l/s	v m/s	Q l/s	v m/s	Q l/s	v m/s	Q l/s	v m/s
0.5	1.6	0.4	1.8	0.4	4.2	0.5	7.4	0.6	12.0	0.7	24.9	0.8	51.6	1.0	82.6	1.1
0.6	1.7	0.4	2.0	0.4	4.7	0.6	8.2	0.6	13.2	0.7	27.4	0.9	56.6	1.0	90.5	1.2
0.7	1.9	0.5	2.1	0.5	5.0	0.6	8.8	0.7	14.2	0.8	29.6	0.9	61.2	1.1	97.8	1.3
0.8	2.0	0.5	2.3	0.5	5.4	0.6	9.4	0.7	15.2	0.8	31.6	1.0	65.4	1.2	104.6	1.4
0.9	2.1	0.5	2.4	0.6	5.7	0.7	10.0	0.8	16.2	0.9	33.6	1.1	69.4	1.3	111.0	1.4
1.0	2.2	0.6	2.6	0.6	6.0	0.7	10.6	0.8	17.1	0.9	35.4	1.1	73.2	1.3	117.1	1.5
1.1	2.3	0.6	2.7	0.6	6.3	0.8	11.1	0.9	17.9	1.0	37.1	1.2	76.8	1.4	122.8	1.6
1.2	2.4	0.6	2.8	0.6	6.6	0.8	11.6	0.9	18.7	1.0	38.8	1.2	80.3	1.5	128.3	1.7
1.3	2.5	0.6	2.9	0.7	6.9	0.8	12.1	1.0	19.5	1.1	40.4	1.3	83.6	1.5	133.6	1.7
1.4	2.6	0.7	3.1	0.7	7.2	0.9	12.5	1.0	20.2	1.1	41.9	1.3	86.7	1.6	138.7	1.8
1.5	2.7	0.7	3.2	0.7	7.4	0.9	13.0	1.0	20.9	1.2	43.4	1.4	89.8	1.7	143.6	1.9
1.6	2.8	0.7	3.3	0.7	7.7	0.9	13.4	1.1	21.6	1.2	44.9	1.4	92.8	1.7	148.3	1.9
1.7	2.9	0.7	3.4	0.8	7.9	0.9	13.8	1.1	22.3	1.2	46.3	1.5	95.6	1.8	152.9	2.0
1.8	3.0	0.8	3.5	0.8	8.1	1.0	14.2	1.1	22.9	1.3	47.6	1.5	98.4	1.8	157.3	2.0
1.9	3.1	0.8	3.6	0.8	8.3	1.0	14.6	1.2	23.6	1.3	48.9	1.6	101.1	1.9	161.7	2.1
2.0	3.2	0.8	3.7	0.8	8.6	1.0	15.0	1.2	24.2	1.3	50.2	1.6	103.8	1.9	165.9	2.1
2.5	3.5	0.9	4.1	0.9	9.6	1.2	16.8	1.3	27.1	1.5	56.2	1.8	116.1	2.1	185.6	2.4
3.0	3.9	1.0	4.5	1.0	10.5	1.3	18.4	1.5	29.7	1.6	61.6	2.0	127.2	2.3	203.3	2.6

# References

## Asia

<b>China</b>	Jin Mao Tower, Shanghai
<b>Hongkong</b>	International Finance Center PH. 1&2, Hongkong
<b>Indonesia</b>	International Airport, Jakarta
<b>Macau</b>	Macau Tower, Macau
<b>Philippines</b>	Pacific Plaza Tower
<b>Singapore</b>	Esplanade Theatre on the Bay, Singapore
<b>Sri Lanka</b>	Kelanitissa Combined Cycle Power Plant, Wellampitiya
<b>Taiwan</b>	Der-Shing Baseball Stadium, Hua-Lien
<b>Vietnam</b>	Opera Hillton Hanoi, Hanoi
<b>Australia</b>	Stadium Australia (2000 Olympic Stadium), Sydney
<b>New Zealand</b>	Ascot Integrated Hospital, Auckland

## Eastern Europe

<b>Bosnia and Herzegovina</b>	Railfeisen Bank, Sarajevo
<b>Bulgaria</b>	Sofia Airport and Catering Facilities, Sofia
<b>Czech Republic</b>	Four Seasons Hotel, Prague
<b>Estonia</b>	Radisson SAS Hotel, Tallin
<b>Hungary</b>	Bridge Köröshegy, Balaton
<b>Kazakhstan</b>	Hotel Intercontinental, Astana
<b>Latvia</b>	National Bank, Riga
<b>Lithuania</b>	President Residence, Vilnius
<b>Macedonia</b>	Macedonian Academy of Science and Art, Skopje
<b>Poland</b>	Warsaw Trade Center, Warsaw
<b>Romania</b>	Sofitel Hotel, Bucharest
<b>Russia</b>	Gazpron Tower, Moscow
<b>Serbia</b>	Mercator Center, Belgrade
<b>Slovenia</b>	Technology Park, Ljubljana
<b>Turkmenistan</b>	President Palace, Ashqabat
<b>Ukraine</b>	Reko Hotel, Kiev
<b>Uzbekistan</b>	Cigarettes Factory Building BAT

## Middle East

<b>Bahrein</b>	Diplomat Hotel
<b>Irak</b>	Aana Rawa Centre
<b>Jordan</b>	Princess Aya Hospital
<b>Kuwait</b>	Meridien Hotel
<b>Lebanon</b>	Beyrouth Terminal Airport, Beyrouth
<b>Lybia</b>	Tripoli Airport
<b>Sultanate of Oman</b>	Salalah Hilton, Salalah
<b>Pakistan</b>	Karachi Airport
<b>Qatar</b>	Sidra Hospital, Doha
<b>Saudi Arabia</b>	King A. Financial District, Riyadh
<b>Syria</b>	Damas University, Damas
<b>Turkey</b>	Kanyon Shopping Mall and Residentials, Istanbul
<b>United Arab Emirates</b>	Landmark Tower, Abu Dhabi

## Europe

<b>Belgium</b>	New European Union building, Brussels
<b>Cyprus</b>	University of Cyprus, Nicosia
<b>Denmark</b>	Mariott Hotel, Copenhagen
<b>Finland</b>	Nokia, office Building Center, Helsinki
<b>France</b>	Stade de France, Paris Plaine St Denis
<b>Germany</b>	World Exhibition Center, Hannover
<b>Great Britain</b>	St Pancras International Station, London
<b>Greece</b>	Athens Metro, Athens
<b>Ireland</b>	Dublin Castle (Re-fit of Soil Pipe), Dublin
<b>Iceland</b>	Keflavik Airport, Reykjavik
<b>Italy</b>	N.A.T.O. Military Bases, Napoli
<b>Luxembourg</b>	European Community Conference Center
<b>Malta</b>	Stock Exchange, Valletta
<b>Netherlands</b>	Tramway Tunnel, The Hague
<b>Norway</b>	Central Oslo Station, Oslo
<b>Portugal</b>	Stadium Benfica, Lisbon
<b>Spain</b>	Prado Museum, Madrid
<b>Sweden</b>	Sky City, Stockholm
<b>Switzerland</b>	Philippe Morris International, Lausanne

## America

<b>Argentina</b>	Newspaper Building "Diario de la Nación", Buenos Aires
<b>Bresil</b>	Copacabana Palace Hotel, Rio de Janeiro
<b>Mexico</b>	French Embassy, Mexico
<b>Peru</b>	Hotel Libertador, Urubamba
<b>Venezuela</b>	Metro, Caracas

## Africa

<b>Algeria</b>	World Trade Center, Algiers
<b>Angola</b>	Sonangol – Corporate Headquarters, Luanda
<b>Botswana</b>	Ministry of Health, Gaborone
<b>Egypt</b>	El Tebbin Power Station, Cairo
<b>Gabon</b>	Tower TOTAL Head Quarter, Libreville
<b>Madagascar</b>	Galaxy II, Antananarivo
<b>Morocco</b>	Grande Mosquée Hassan II, Casablanca
<b>Niger</b>	Gawage Hotel, Niamey
<b>Nigeria</b>	New Central Bank of Nigeria CBN, Abuja
<b>South Africa</b>	United States of America Embassy, Cape Town
<b>Tanzania</b>	British High Commission
<b>Tchad</b>	Five Stars Hotel, N'Djamena
<b>Tunisia</b>	Hammamet Sheraton Hotel, Hammamet